

Universal monitoring module

# GPRS-A Lite

Firmware version 2.00

EN

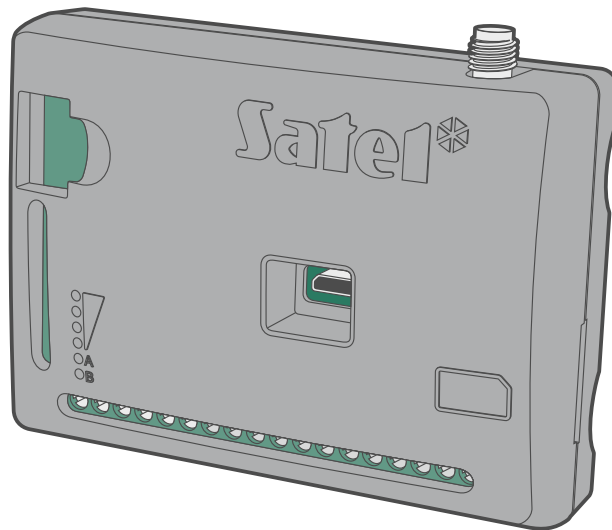

CE

gprs-a\_lite\_en 03/23

**Satel**®

SATEL sp. z o.o. • ul. Budowlanych 66 • 80-298 Gdańsk • POLAND  
tel. +48 58 320 94 00  
[www.satel.pl](http://www.satel.pl)

## IMPORTANT

The module should be installed by qualified personnel.

Prior to installation, please read carefully this manual in order to avoid mistakes that can lead to malfunction or even damage to the equipment.

Disconnect power before making any electrical connections.

Changes, modifications or repairs not authorized by the manufacturer shall void your rights under the warranty.

The rating plate of the device is located on the enclosure base.



The device meets the requirements of the applicable EU directives.



The device is designed for indoor installation.



The device must not be disposed of with other municipal waste. It should be disposed of in accordance with the existing rules for environment protection (the device was placed on the market after 13 August 2005).



The device meets the technical regulations of the Eurasian Customs Union.

FreeRTOS is used in this device ([www.freertos.org](http://www.freertos.org)).

SATEL aims to continually improve the quality of its products, which may result in changes in their technical specifications and software. The current information on the introduced modifications is available on our website.

Please visit us:

<https://support.satel.pl>

**Hereby, SATEL sp. z o.o. declares that the radio equipment type GPRS-A Lite is in compliance with Directive 2014/53/EU. The full text of the EU declaration of conformity is available at the following internet address: [www.satel.pl/ce](http://www.satel.pl/ce)**

The following symbols may be used in this manual:



- note,



- caution.

## CONTENTS

1. Introduction.....	3
2. Features .....	3
3. Typical module applications .....	4
3.1 Supervision / control of devices .....	4
3.2 Simulation of monitoring station.....	5
4. Description of the module.....	6
4.1 LED indicator .....	7
5. Installation .....	8
5.1 Preparing the cabling.....	8
5.2 Installation of the module.....	8
5.3 Installation of antenna.....	8
5.4 Connecting the alarm control panel .....	8
5.5 Connecting the devices to the inputs and outputs .....	8
5.6 Connecting the power supply and starting the module.....	9
5.7 Connecting the computer to the module .....	9
5.8 Installing the SIM card .....	9
6. Programming.....	10
6.1 Description of the GX Soft program .....	10
6.1.1 Startup window.....	10
6.1.2 Menu bar in the GX Soft program .....	12
6.1.3 Side menu .....	13
6.1.4 Status panel .....	13
6.1.5 Additional menu .....	13
6.2 Establishing connection between the program and the module .....	16
6.2.1 Local connection .....	16
6.2.2 Remote connection: SATEL server.....	16
6.2.3 Remote connection: Module > GX Soft.....	17
6.3 Project.....	17
6.4 Hardware .....	18
6.4.1 Mainboard .....	18
6.4.2 GSM .....	20
6.5 Inputs .....	22
6.5.1 Status .....	22
6.5.2 Settings .....	22
6.5.3 Bypasses.....	23
6.6 Outputs .....	23
6.6.1 Control.....	23
6.6.2 Settings .....	23
6.6.3 Triggering.....	25
6.7 Communication .....	25
6.7.1 SATEL server.....	26
6.7.2 Direct connection to GX Soft.....	26
6.8 Station simulation.....	26
6.9 Reporting .....	28
6.10 Messaging.....	32
6.11 Event converter.....	33
6.12 SMS control .....	35
6.13 CLIP control .....	37
6.14 Remote update .....	40
6.15 Users.....	41
6.16 Events.....	42
7. Control by using a telephone.....	43
7.1 SMS control .....	43
7.2 CLIP control .....	43
8. Module firmware update .....	44
8.1 Local update .....	44
8.2 Remote update .....	44

---

8.2.1	Initiating the update by using SMS message.....	44
9.	Restoring the factory settings .....	45
10.	Specifications .....	45

## 1. Introduction

---

This manual describes the GPRS-A Lite module and how it should be installed as well as configured using the GX Soft program.

## 2. Features

---

### Communication

- Built-in telephone designed for use in the 2G and 4G cellular networks.
- Possibility to remotely check the account balance and validity of the SIM card installed in the module.
- Possibility to define the MCC / MNC code of the operator of network into which the module is to log in.

### Reporting

- Reporting events to two monitoring stations.
- Several communication formats:
  - SIA,
  - Contact ID (CID),
  - Ademco Express,
  - Sil. Knight / Ademco slow,
  - Radionics 1400Hz,
  - Radionics 1400 with parity.
- Two transmission paths:
  - GPRS / LTE,
  - SMS messages.
- Defining priority for the paths of event reporting.
- Converting and retransmitting codes of events received from the control panel (simulation of telephone monitoring station).

### Messaging

- Notification of events related to the module and received from other devices.
- 8 telephone numbers to be notified.
- Notification by using:
  - SMS messages,
  - CLIP (toll-free).

### Event log

- Capability of storing up to 500 events generated by the module or received from the control panel.

### Inputs

- 4 inputs, programmable as:
  - digital, NO type,
  - digital, NC type.
- Input for supervision of AC voltage presence.

- Supervising the status of external devices.
- Capability of input bypassing.

### **Outputs**

- 4 programmable OC type outputs.
- Controlling external devices or signaling troubles.

### **Control**

- Control of outputs or bypassing of the module inputs by means of:
  - inputs,
  - SMS messages,
  - GX Soft program,
  - CLIP (only outputs control).
- Capability of determining the telephone numbers authorized for SMS or CLIP control.

### **Programming**

- Free GX Soft program for local (USB (Micro-B) port) and remote (data transfer via cellular network) programming of the module.
- Simple and easy establishing remote communication between GX Soft program and the module thanks to SATEL's connection setup service.
- Possibility to configure the module settings by using SMS messages.

### **Firmware update**

- Local firmware update by using a computer connected to USB (Micro-B) port.
- Remote update of the module firmware by using the "UpServ" server via cellular network.

### **LEDs**

- LEDs indicating the module status.

### **Power supply**

- Powering with 12 VDC ( $\pm 15\%$ ).

## **3. Typical module applications**

---

The extended functionality of GPRS-A Lite module enables it to be used for a variety of applications. This section presents typical examples of its application. Some of them are capable of being combined with one other.

### **3.1 Supervision / control of devices**

---

Changing the input status may result in:

- sending event code to the monitoring station (reporting GPRS/LTE or SMS),
- notification (messaging) about the event by means of SMS or CLIP.

The inputs can be bypassed locally (by means of one of the module inputs or the GX Soft program) or remotely (by means of SMS messages or the GX Soft program).

The devices connected to the module outputs can be controlled locally (by means of module inputs or the GX Soft program) or remotely (by means of SMS messages, CLIP or the GX Soft program).

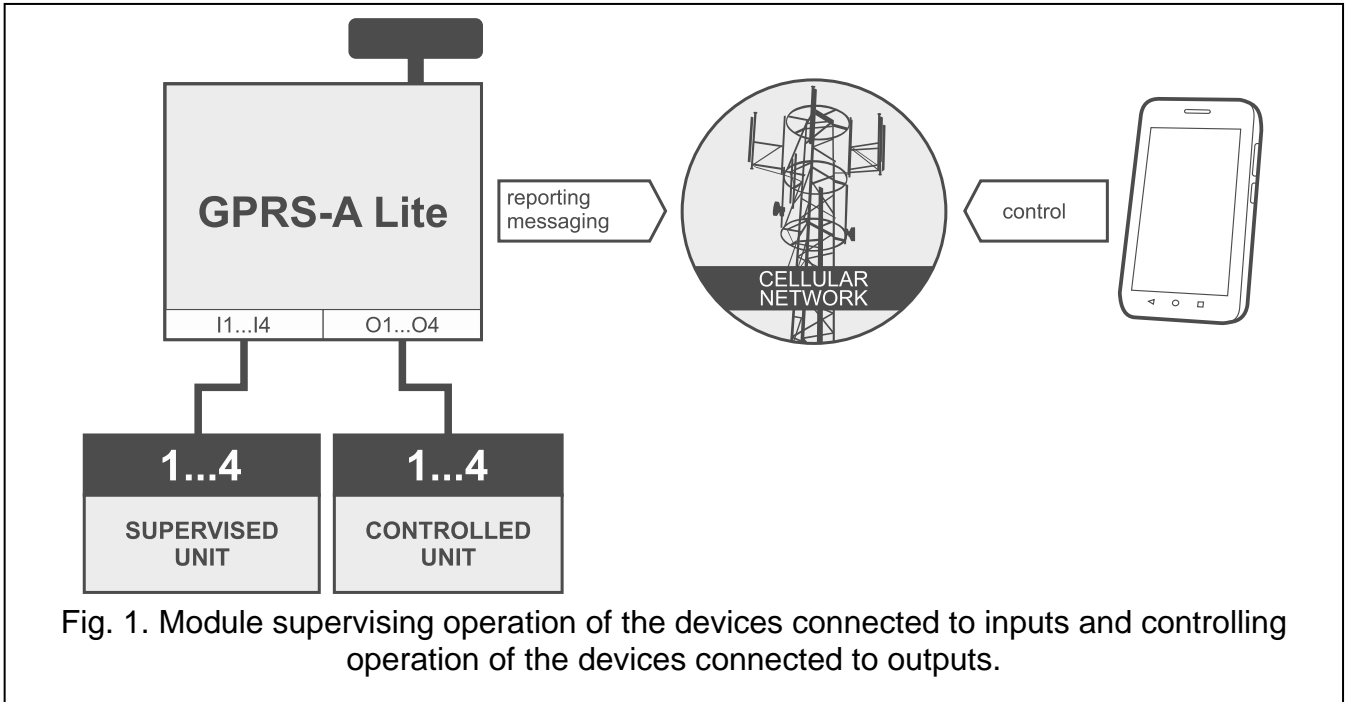

Fig. 1. Module supervising operation of the devices connected to inputs and controlling operation of the devices connected to outputs.

### 3.2 Simulation of monitoring station

The module can forward the event codes received from the control panel to the monitoring station by means of cellular network. Which reporting path will be used to send the event code depends on the module configuration.

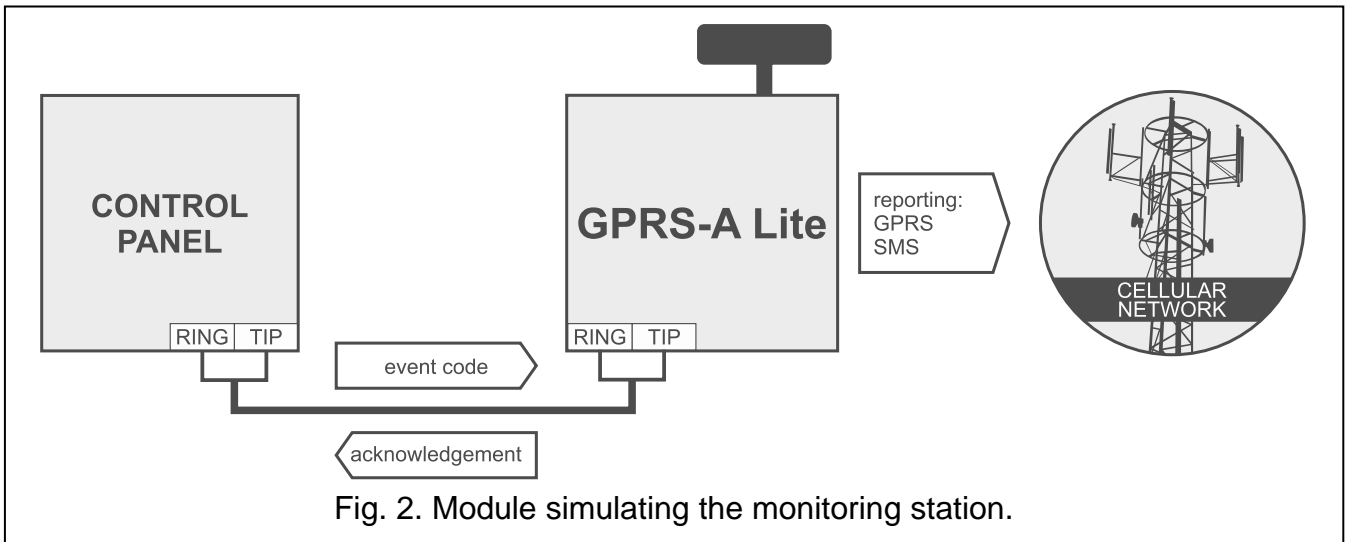

Fig. 2. Module simulating the monitoring station.

## 4. Description of the module

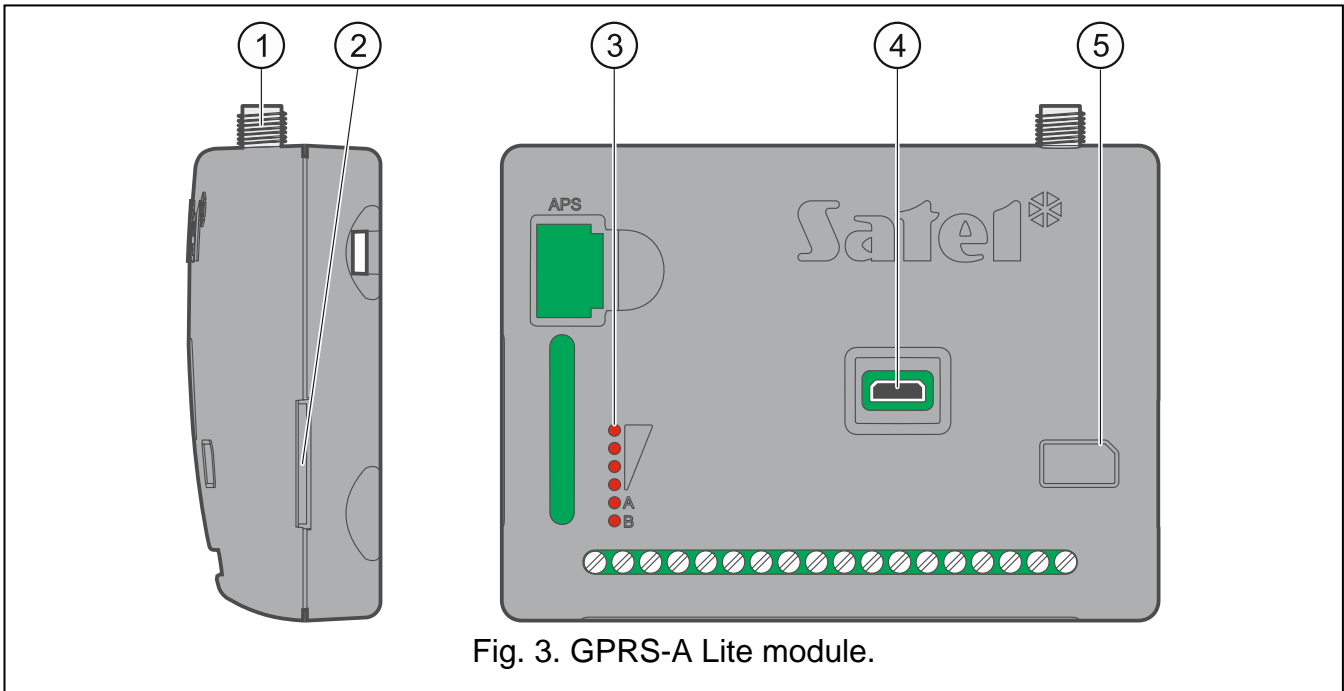

Fig. 3. GPRS-A Lite module.

- ① antenna connector (the antenna is delivered with the module).
- ② SIM card slot.
- i** *Inserting the SIM card into its slot before programming the card PIN code in the module is not recommended (if the card requires entering the PIN code).*
- ③ LEDs indicating the module status (see “LED indicator”).
- ④ port USB (Micro-B).
- ⑤ information on how to install the SIM card.

### Description of terminals

- +12V** – power input (12 VDC  $\pm$ 15%).
- COM** – common ground.
- RING, TIP** – terminals for connecting the control panel telephone communicator.
- I1...I4** – inputs (NC or NO type).
- O1...O4** – programmable OC type outputs (disconnected from common ground / shorted to common ground).
- AC** – input for supervision of AC voltage presence.



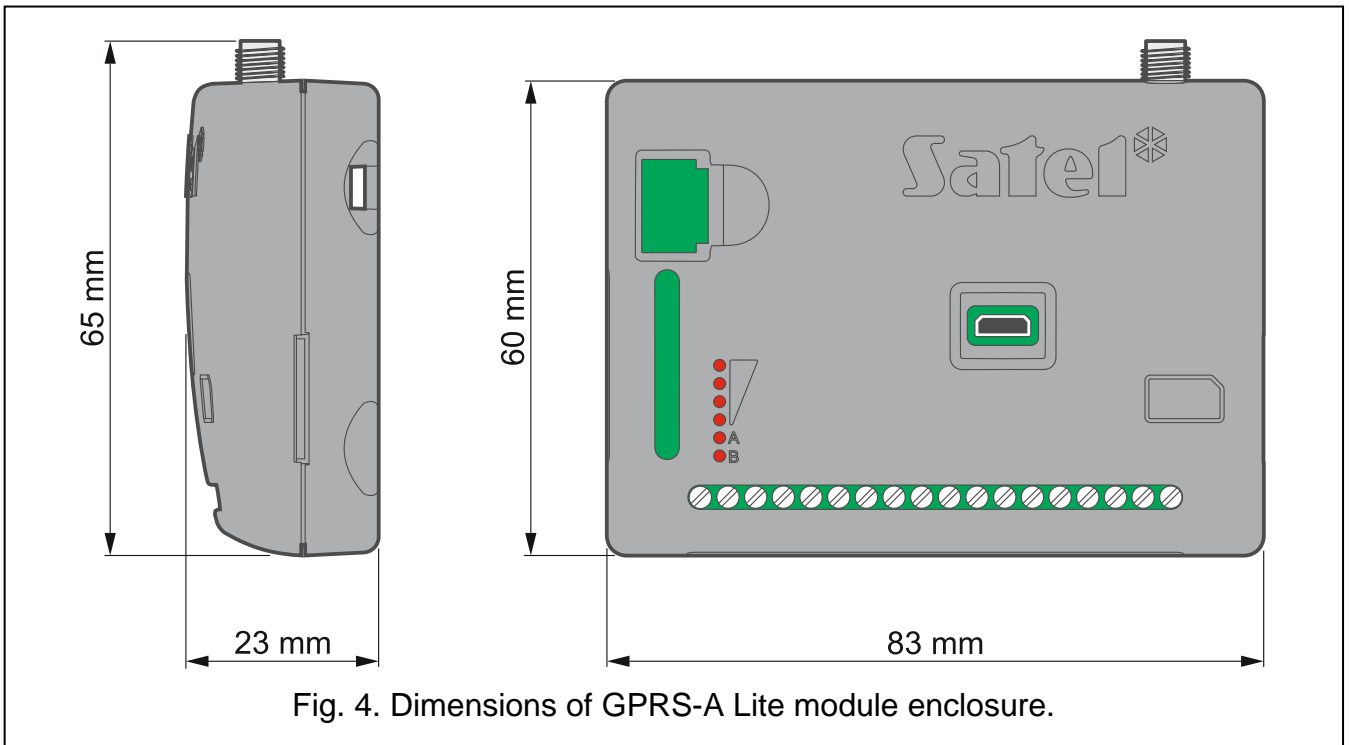

Fig. 4. Dimensions of GPRS-A Lite module enclosure.

### 4.1 LED indicator

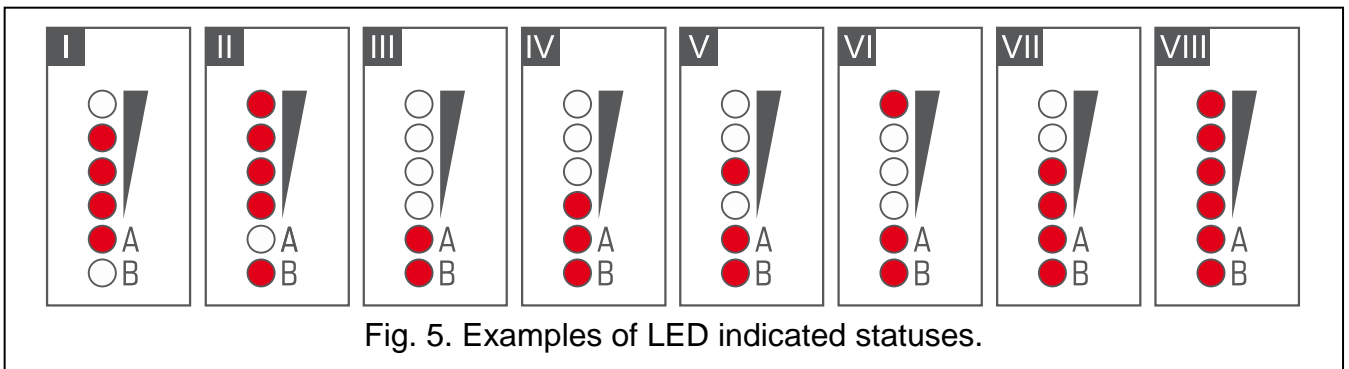

Fig. 5. Examples of LED indicated statuses.

- I** (LED A is flashing, the other LEDs are ON) – data transmission is going on; signal level: 3.
- II** (LED B is flashing, the other LEDs are ON) – SMS message is being sent, module is calling (CLIP); signal level: 4.
- III** (LEDs are flashing) – logging into cellular network.
- IV** (LEDs are flashing) – logging into cellular network has failed; missing SIM card.
- V** (LEDs are flashing) – logging into cellular network has failed; incorrect PIN code.
- VI** (LEDs are flashing) – logging into cellular network has failed; SIM card has been blocked after three attempts to use an invalid PIN code (PUK code must be used to unblock the SIM card).
- VII** (LEDs are flashing) – cellular phone is disabled (see “SIM” option p. 20).
- VIII** (LEDs are flashing) – module waiting for configuration settings to be loaded.

---

## 5. Installation

---



**Disconnect power before making any electrical connections.**

**It is not advisable to power up the module if the antenna is not connected.**

**The installation to which the module is to be connected should be provided with:**

- **2-pole disconnector,**
- **short-circuit protection with a 16 A time delay circuit breaker.**

The GPRS-A Lite module should be installed indoors, in spaces with normal air humidity. When selecting the mounting location, remember that thick masonry walls, metal partitions, etc. will reduce the range of radio signal. It is not advisable to install the module in close vicinity to electrical installations, because this can result in malfunctioning of the device.

---

### 5.1 Preparing the cabling

---

Run the cables to be used for connecting the module with other devices to the module installation place. Do not lay the cables in immediate vicinity of the low-voltage electrical network wires, especially those used for supplying the high-power equipment (such as electric motors).

It is recommended that unshielded non-twisted cable to be used.

---

### 5.2 Installation of the module

---

The module enclosure base makes it possible to secure the module to the mounting surface by using e.g. a cable tie or angle hooks.

---

### 5.3 Installation of antenna

---

The GPRS-A Lite module is delivered with an antenna. The antenna can be replaced with another antenna mounted on the enclosure or at some distance from it.

Using the antenna mounted at some distance from the enclosure is recommended wherever thick masonry walls, metal partitions etc. may decrease the range of radio signal at the module installation place.

The antenna must not be installed in parallel to low-voltage electrical wires, or it can affect performance of the antenna.

---

### 5.4 Connecting the alarm control panel

---

Connect the control panel telephone communicator to the TIP and RING terminals.

---

### 5.5 Connecting the devices to the inputs and outputs

---

1. Connect the devices whose operation is to be monitored by the module to the input terminals.
2. If the module is to be powered from the SATEL APS-15 or APS-30 power supply, you can connect to the AC input terminal the wire from the secondary winding of the transformer which supplies the AC voltage to the power supply (Fig. 6). This will enable the GPRS-A Lite module to supervise the presence of AC voltage.
3. Connect the devices which are to be controlled by the module to the terminals of outputs.

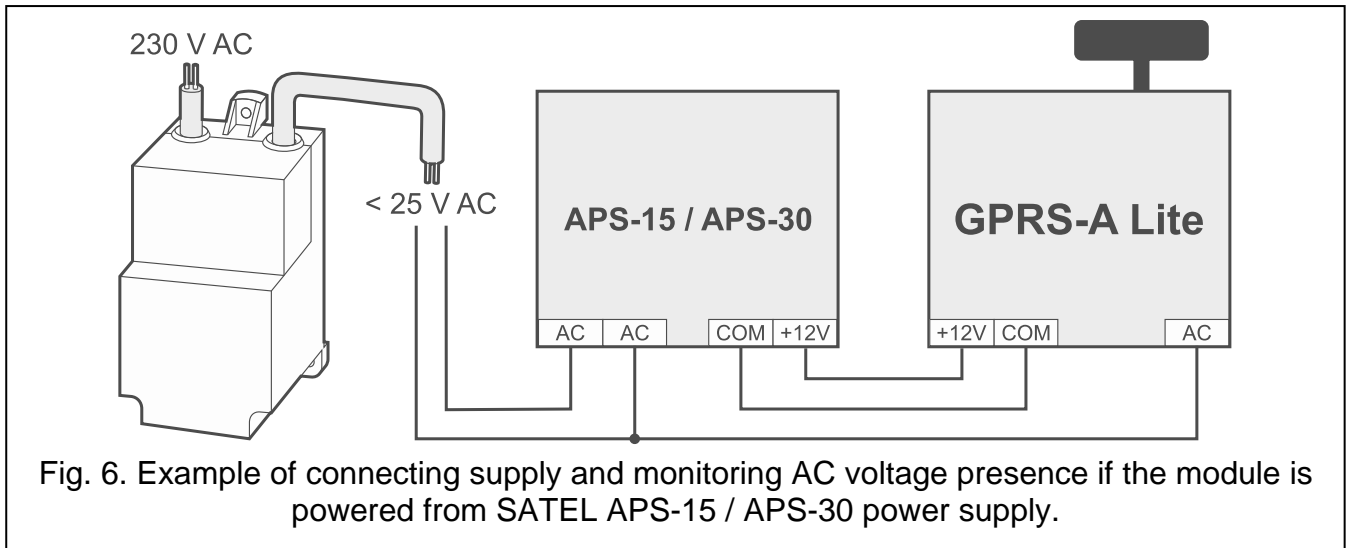

## 5.6 Connecting the power supply and starting the module

The module may be powered from the control panel, from an expander with power supply, or from a 12 VDC power supply.



*The required output current of power supply is at least 500 mA.*

1. Connect the power supply unit to the APS connector or connect the power leads to the +12V and COM terminals (use flexible conductors with a cross-section of 0.5-0.75 mm<sup>2</sup>).
2. Power up the module. The module will start up.

## 5.7 Connecting the computer to the module

Connect the module USB port (Micro-B) to the computer USB port. The Windows system will automatically detect that a new device has been connected. Having connected the computer to the module, you can:

- configure the module by using the GX Soft program. You can download the GX Soft program from the [www.satel.pl](http://www.satel.pl) website. For more information, please refer to section "Programming" (p. 10).
- update the module firmware.

## 5.8 Installing the SIM card

1. If PIN code is required by the SIM card, use the GX Soft program to program the code (see p. 20).
2. Power down the module.
3. Insert the SIM card into its slot as shown on the enclosure.
4. Power up the module. Logging the telephone into the cellular network may take a few minutes.



*If the module is to send data via the cellular network, it is recommended that you use SIM cards with a dedicated tariff plan for M2M (machine-to-machine) communication.*

*If the programmed PIN code is invalid, the module will report a trouble. Programming a correct PIN code will clear the trouble.*

*Restarting the module with a wrongly programmed PIN code three times will block the SIM card. To unblock the SIM card, remove it and insert into a mobile phone. Then, enter the PUK code.*

## 6. Programming

You can configure all the module settings by using a computer with GX Soft program installed. Required program version: 2.1.1 (or newer).

Communication between the computer and the module can take place locally (via USB (Micro-B) port) or remotely (via cellular network).

Module with factory settings can only be programmed locally. Remote programming is only possible after settings for communication via cellular network (see p. 20). Communication between the program and the module is encrypted.

Having programmed the SMS control commands in the module (see “SMS control” p. 35), you can configure some working parameters of the module by using SMS messages.

### 6.1 Description of the GX Soft program

Access to the program can be password protected (see “Settings” window” p. 15).

#### 6.1.1 Startup window

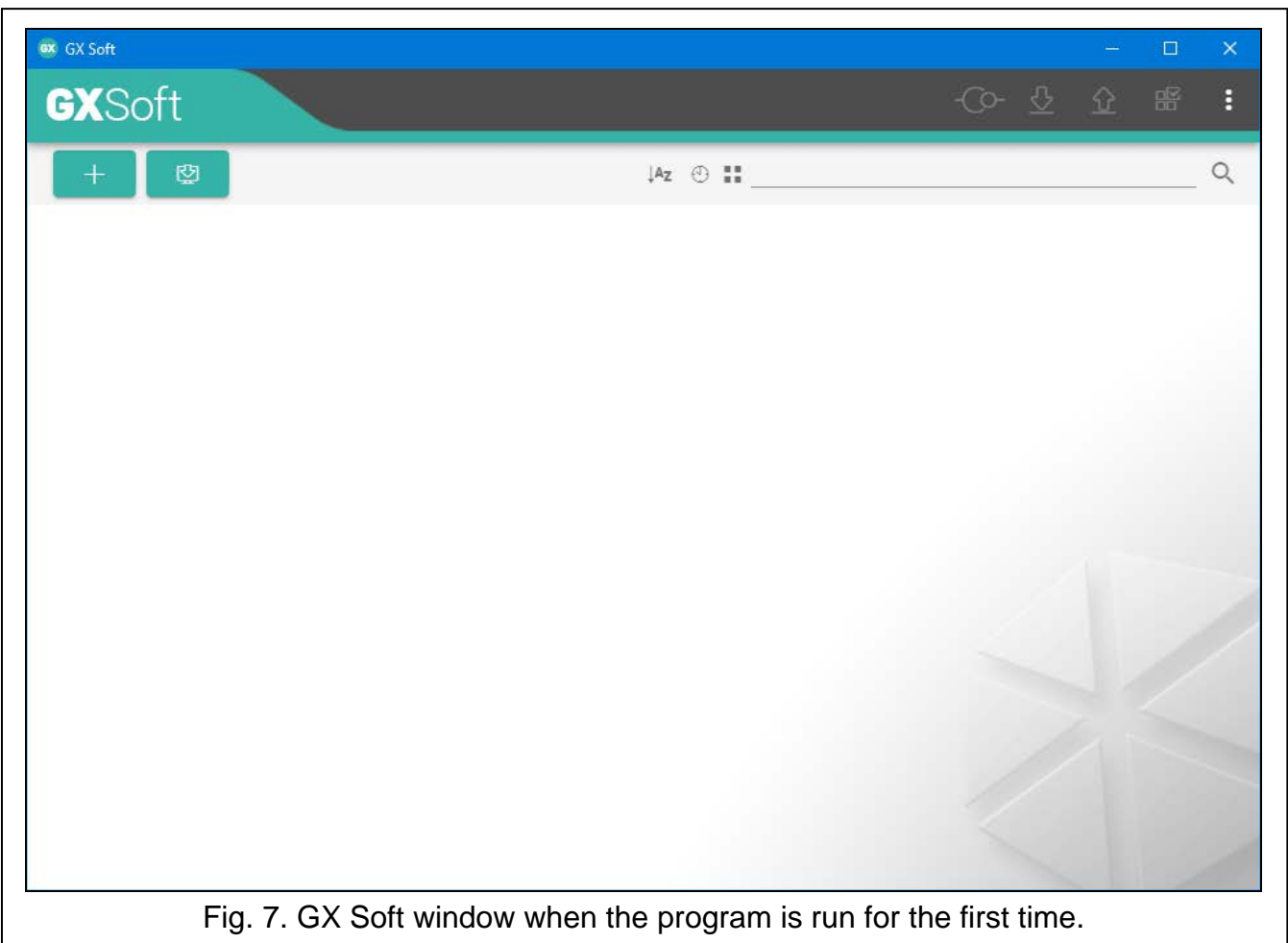









Fig. 7. GX Soft window when the program is run for the first time.

In this window you can manage projects created in the GX Soft program.

#### **Buttons**

	click to update the GX Soft program. The button is displayed when new program version is available.
	click to add a new project with module factory default settings.

-  click to import a project with module settings.
- Az click, if the projects are to be sorted by name (the arrow next to the button indicates whether the projects are displayed from A to Z or from Z to A). This button is displayed if project details are presented in brief version.
-  click, if the projects are to be sorted by the time they were saved to disk (the arrow next to the button indicates whether the projects are displayed in the descending or ascending order). The button is displayed if project details are presented in brief version.
-  click, if project details are to be presented in brief version.
-  click, if project details are to be presented in full version.
-  click to delete the project. The button is displayed when you hover the mouse over the project.

### Search field

The search field is displayed in the top part of the window. If you want to find a project file:

1. Click on the search field and enter a string of characters included in the file details (e.g. the project name or date created).
2. Click . Projects that meet the search criteria will be displayed.

 *If you want to display all projects, click  in the search field (this will clear all the characters entered in the field).*

### Sorting projects

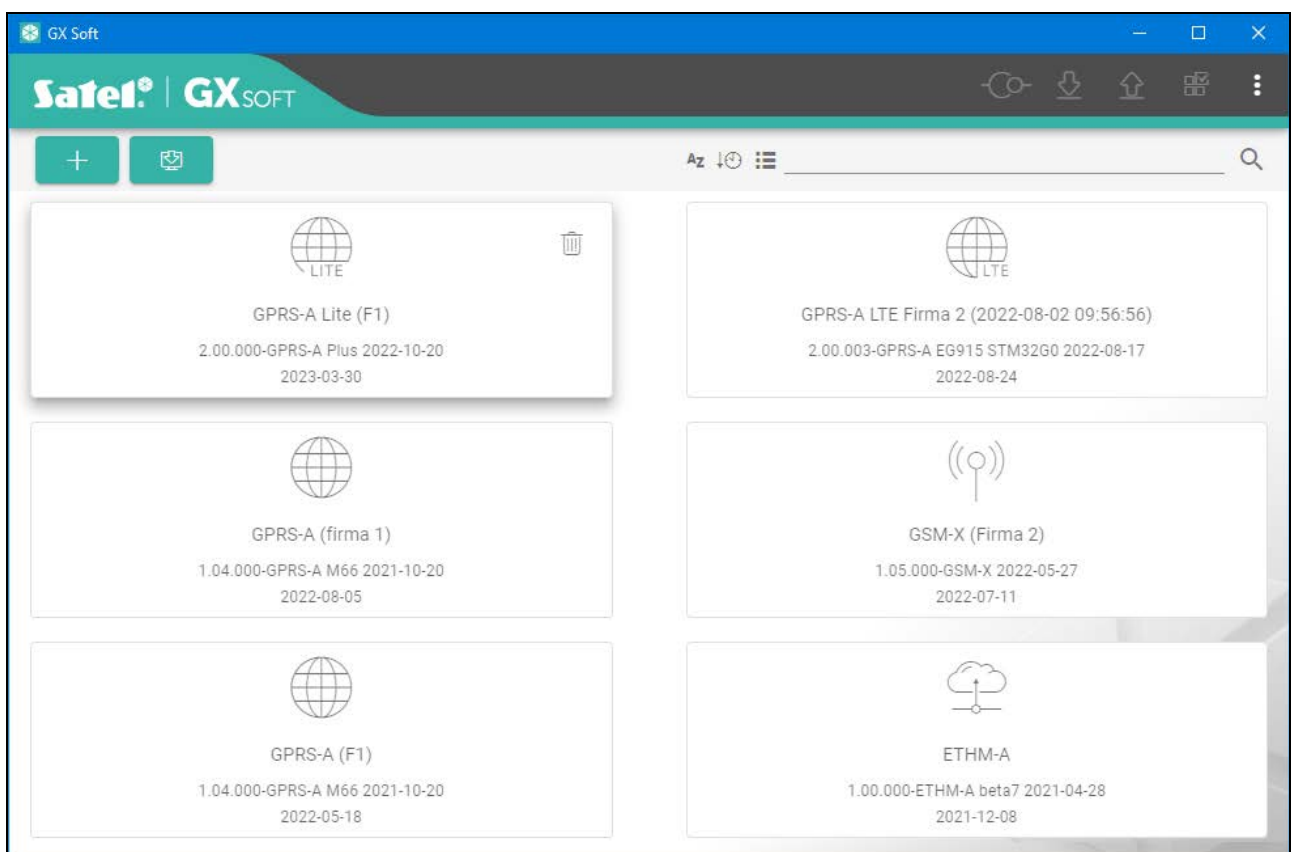

Fig. 8. GX Soft startup window with examples of projects.

If the project details are presented in full version, click on the selected column header (e.g. "Project name") to sort the list by the data in that column. The symbol indicating the current sorting method (↑ – ascending, ↓ – descending) will be displayed in the column header.

### 6.1.2 Menu bar in the GX Soft program

The menu bar is displayed in the top part of the program window. Appearance of the menu bar depends on the contents presented in the window.

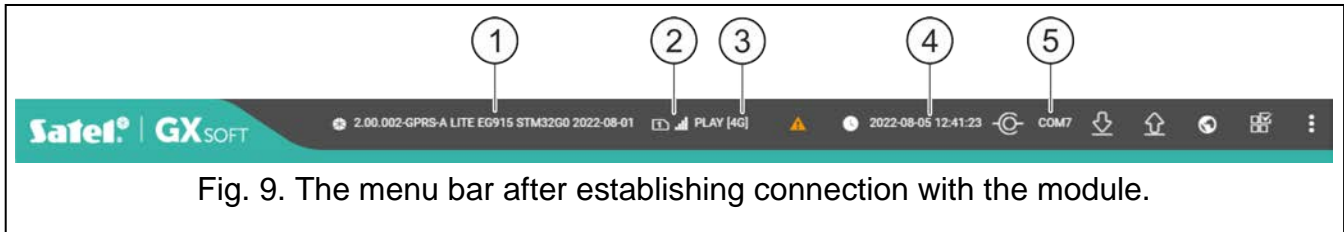

Fig. 9. The menu bar after establishing connection with the module.





- ① module firmware version (number and date of compilation), type of module and type of module cellular telephone.
- ② information about the SIM card used, cellular signal level and operator of the cellular network used by the module.
- ③ type of cellular network.
- ④ date and time according to the module clock (local time, taking into account the time zones). When you hover the mouse over the field, the time used by the module clock is displayed (Greenwich Mean Time (GMT)).
- ⑤ information on the way of communication with the module:  
 COM – local connection,  
 SRV – remote connection (cellular network) through the SATEL server,  
 TCP – remote connection (cellular network) directly to the module.  
 Click on the text to display information on the connection status.

#### Buttons

	click to display the list of troubles.
	click to update date and time in the module.
	click to establish connection to the module. The button is displayed when the program is not connected to the module.
	click to finish connection to the module. The button is displayed when the program is connected to the module.
	click to read data from the module.
	click to write data to the module. If data entered in the program are invalid (e.g. format is wrong or value is outside defined range), a red dot will be displayed on the button: . Invalid data will not be written to the module.
	click to send a test transmission to the monitoring station.
	click to display the status panel. The button is available after connection to the module is established.
	click to display the additional menu.

### 6.1.3 Side menu





The side menu is displayed on the left side of the program window after you open a project. The buttons displayed in the menu open the tabs used for configuration of the module settings. If data entered in the tab are invalid, a red dot will be displayed on the button.

	click to minimize the menu.
	click to display full menu.
	click to display submenu.
	click to hide submenu.



### 6.1.4 Status panel

The status panel is displayed after you click .

#### Status of inputs

-  input not used. The “OFF” option is selected in the “Type” field (see “Type” p. 22).
-  input in normal status (not violated). Click to bypass the input.
-  input violated. Click to bypass the input.
-  input bypassed. Click to unby pass the input.

#### Status of outputs

-  output inactive. Click to activate the output.
-  output active. Click to deactivate the output.

### 6.1.5 Additional menu

The additional menu is displayed after you click . Appearance of the menu depends on the contents presented in the window.

**Open** – click to open a project.

**Save** – click to save the module data to file.

**Export** – click to export the file with module data.

**Connection** – click to open the “Connection” window.

**Settings** – click to open the “Settings” window.

**About** – click to display information about the program.

#### “Connection” window

In the window, you can choose how connection with the module is to be established:

- if the module is to be programmed locally from the computer connected to the USB (Micro-B) port of the module, select “COM”,
- if the module is to be programmed remotely through SATEL server via cellular network, select “SATEL SERVER”,
- if the module to be programmed remotely via cellular network, but the module is to connect directly to the program, select “MODULE > GX SOFT”.

**Module key** – a string of characters for identification of the module. It must be identical to that programmed in the module (see “Communication” p. 25). Click  to view the key.

#### COM

Select from the list a COM port of the computer through which communication with the USB (Micro-B) port of module is to take place.

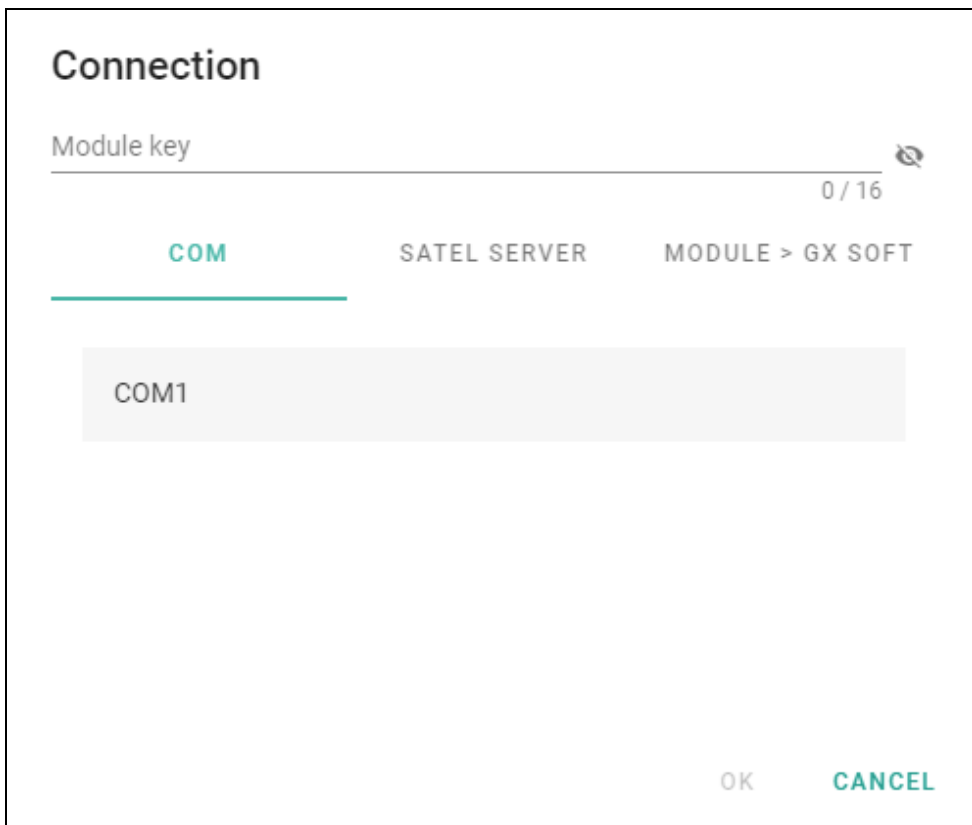

Fig. 10. "Connection" window: local connection settings.

**SATEL SERVER**

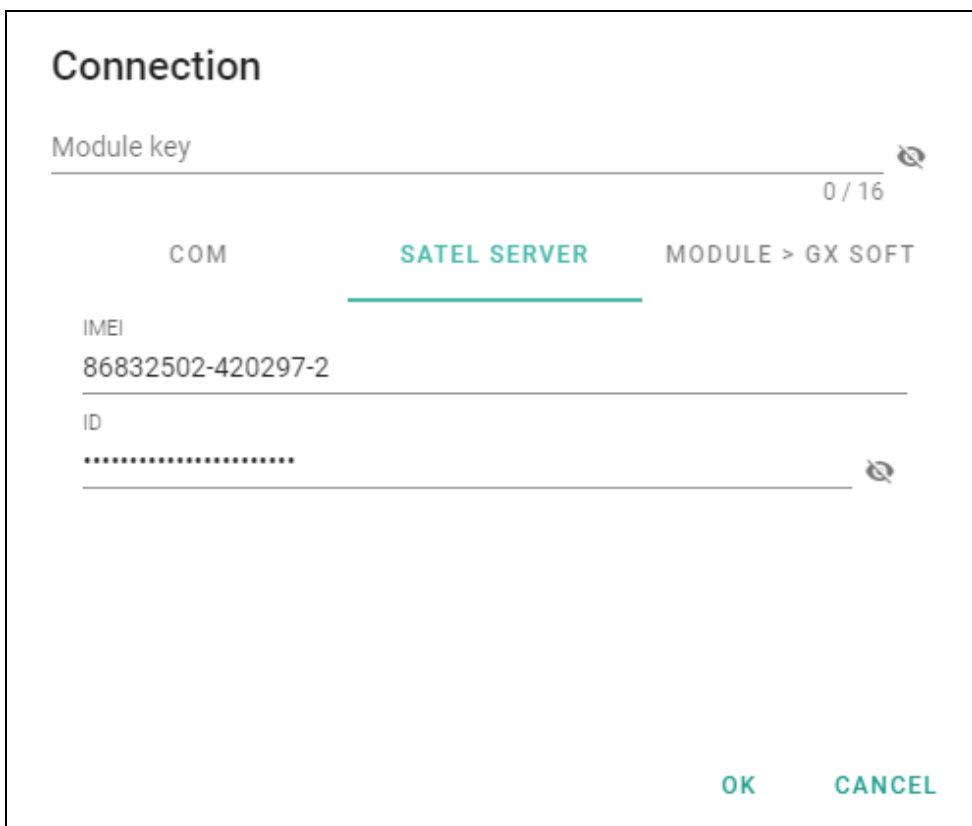



Fig. 11. "Connection" window: settings for establishing connection through SATEL server.



**IMEI** – individual identification number of the module cellular telephone.

**ID** – individual identification number for the purposes of communication through the SATEL server. The number is assigned automatically by the SATEL server during the first connection to the server (before the number is assigned, “F” characters are displayed). Click  to view the number.

### **MODULE > GX SOFT**

**Port** – number of the port on which the computer with GX Soft program is awaiting the incoming connections from the module.

### **Buttons**

**OK** – click to confirm the changes.

**Cancel** – click to close window without saving changes.

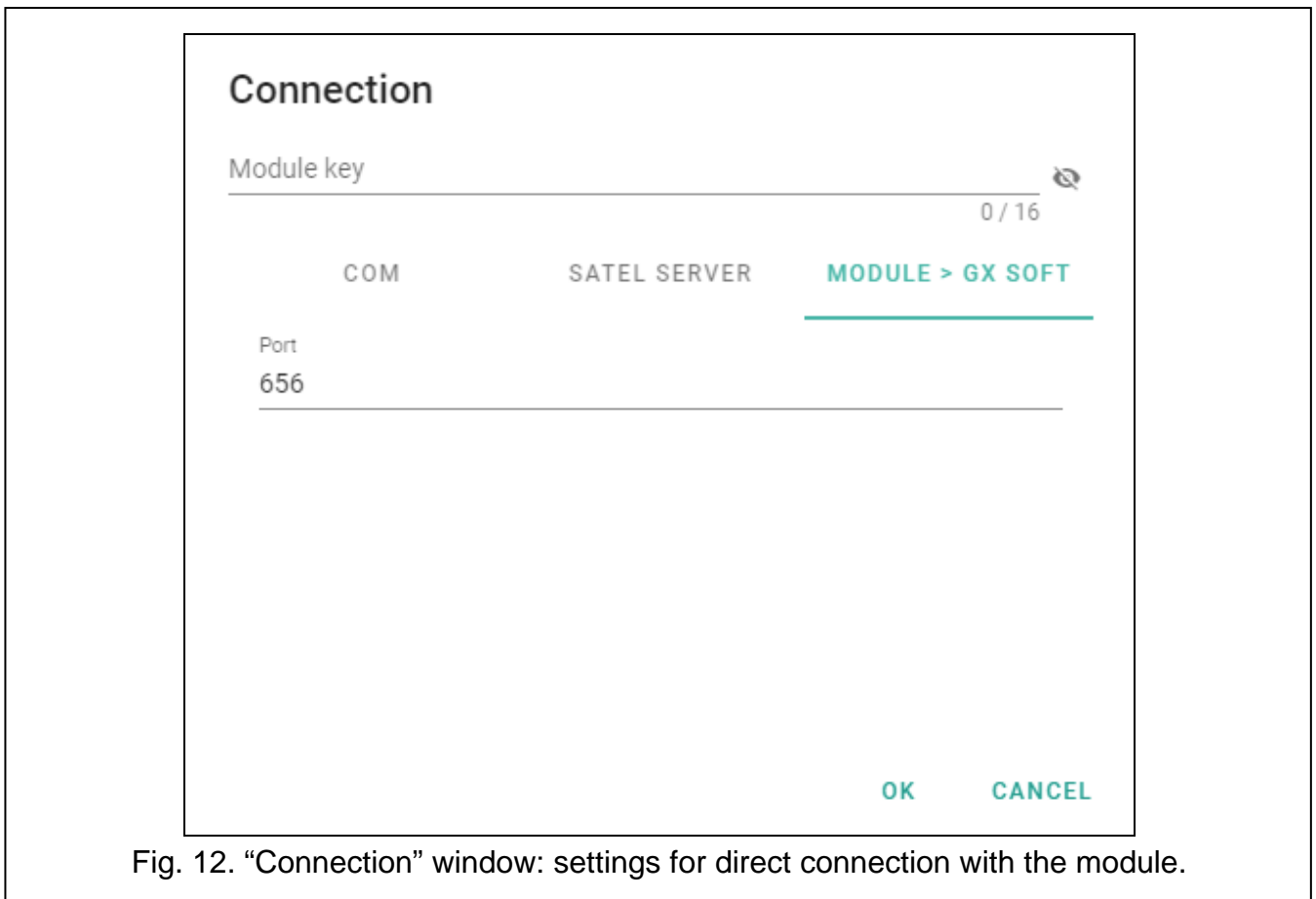

Fig. 12. “Connection” window: settings for direct connection with the module.

### **“Settings” window**

#### **Password protection**

You can enter the password to protect the program against unauthorized access.



the program is not password protected. Click to enable the password protection.



the program is password protected. Click to disable the password protection

**GX Soft password** – program access password. Click  to view the password.

**Confirm GX Soft password** – password verification. Click  to view the password.

**IMEI** – individual identification number of the module cellular phone. The field is available if the program reads the IMEI number from the module or from the module data file.

**Application language** – you can select a program language.

### Buttons

**OK** – click to save changes.

**Cancel** – click to close window without saving changes.

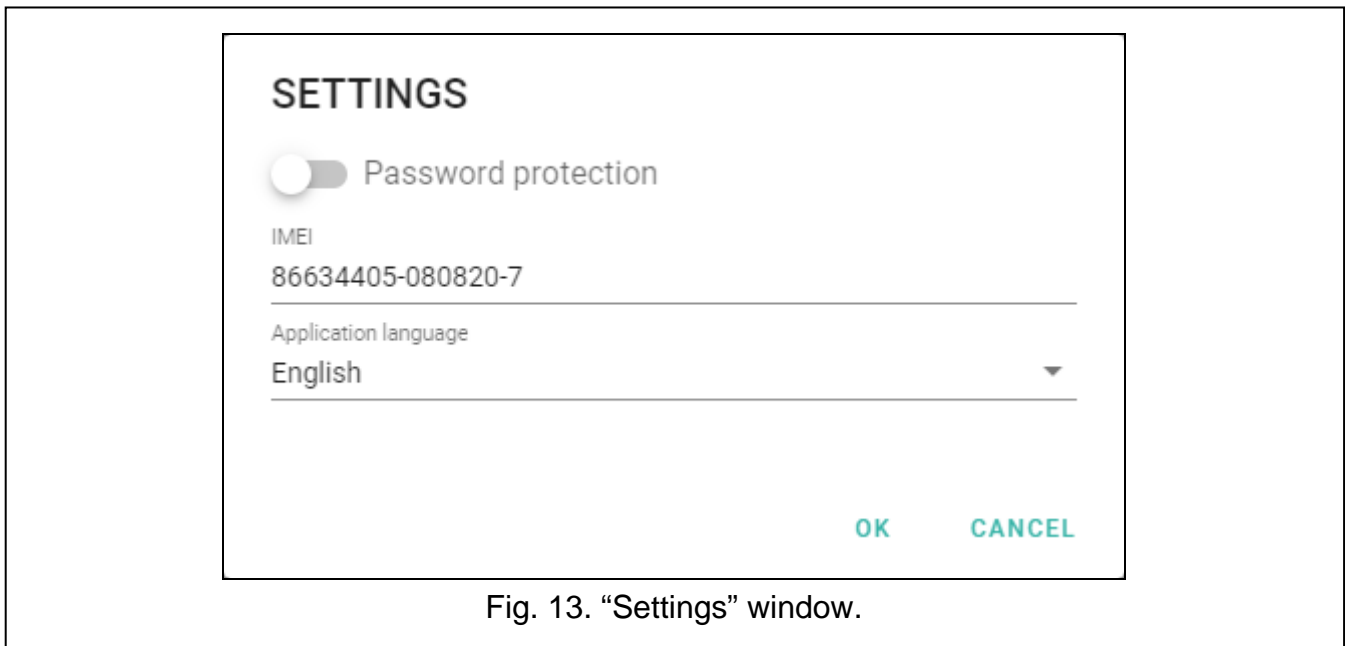

Fig. 13. "Settings" window.

## 6.2 Establishing connection between the program and the module



*Establishing connection is possible, if an identical "Module key" has been programmed in the module and in the program, except for the module with factory settings.*

*If you program an incorrect IMEI number, connection with the module will only be possible after changing the IMEI number in the module (the message will be displayed before the connection is established: "MAC / IMEI / ID will be changed. You will also lose the event log in the project.. Do you want to continue?").*

### 6.2.1 Local connection

1. Connect the module USB (Micro-B) port with the computer port.
2. In the startup window, open the file with module data (a file with default settings or a previously saved file).
3. In the "Connection" window, "COM" tab, select the module that you want to connect to (see "Connection" window" p. 13).
4. Click  on the menu bar.
5. A window will open with information that connection has been established and a prompt to read the data.
6. Click "Yes" if you want to read the data stored in the module.

### 6.2.2 Remote connection: SATEL server



*The "Connect to GX Soft" option must be enabled in the module (see "Communication" p. 25). By default, this option is disabled.*

1. In the startup window, open the file with module data (a file with default settings or a previously saved file).

2. In the “Connection” window, “SATEL SERVER” tab, configure the settings required to establish connection through the SATEL server (see ““Connection” window” p. 13).
3. Click  on the menu bar.
4. A window will open with information that connection has been established and a prompt to read the data.
5. Click “Yes” if you want to read the data stored in the module.

### 6.2.3 Remote connection: Module > GX Soft



*The computer running the GX Soft program must have a public IP address.*

*A control command, after receiving of which the module will make an attempt to establish connection, must be programmed in the module (see “Direct connection to GX Soft” p. 26).*

1. In the startup window, open the file with module data (a file with default settings or a previously saved file).
2. In the “Connection” window, “MODULE > GX SOFT” tab, configure the settings required to establish direct connection via cellular network (see ““Connection” window” p. 13).
3. Click  on the menu bar.
4. Send an SMS message with the following content to the number of SIM card currently used by the module:
  - xxxx** (“xxxx” – control command that initiates establishing connection with the GX Soft program) – the module is to connect to the computer whose address has been programmed in the module,
  - xxxx=aaaa:p=** (“xxxx” – control command that initiates establishing connection with the GX Soft program; “aaaa” – address of the computer running the GX Soft program; “p” – TCP port) – the module is to connect to the computer whose address has been given in the SMS message and use for communication the TCP port given in the SMS message. The “Server address from SMS” option must be enabled in the module (p. 26).
5. After the module connects to the computer, a window will open with information that connection has been established and a prompt to read the data.
6. Click “Yes” if you want to read the data stored in the module.

## 6.3 Project

---

The tab allows entering data for easier identification of the project created.

**Project name** – individual name of the project.

**Owner** – name of the project owner.

**Address** – project owner address data.

**Contact telephone** – project owner contact telephone number.

**Created by** – name of the project author.

**Created at** – date when the project was created.

**Updated at** – date when the project was last updated.

**Synchronized at** – date when the data from the module were last written / read.

**Telephone numbers synchronized at** – date when the additional telephone numbers for CLIP control from the module were last written / read.

**Module telephone number (SIM)** – telephone number of SIM card installed in the module.

**Notes** – additional information / notes stored in the project.

**Note (stored in module)** – additional information / notes stored in module memory.

**Firmware version** – module firmware version: number and date of compilation.

**Radio firmware version** – version number of radio firmware.

**IMEI** – individual identification number of the module cellular telephone.

**ID** – individual identification number of the module for the purposes of communication through the SATEL server (assigned automatically by the SATEL server). Click  to view the number.

**Factory settings** – click to restore module factory settings. A message box will be displayed in which you must confirm your intention to restore the factory settings of the module.

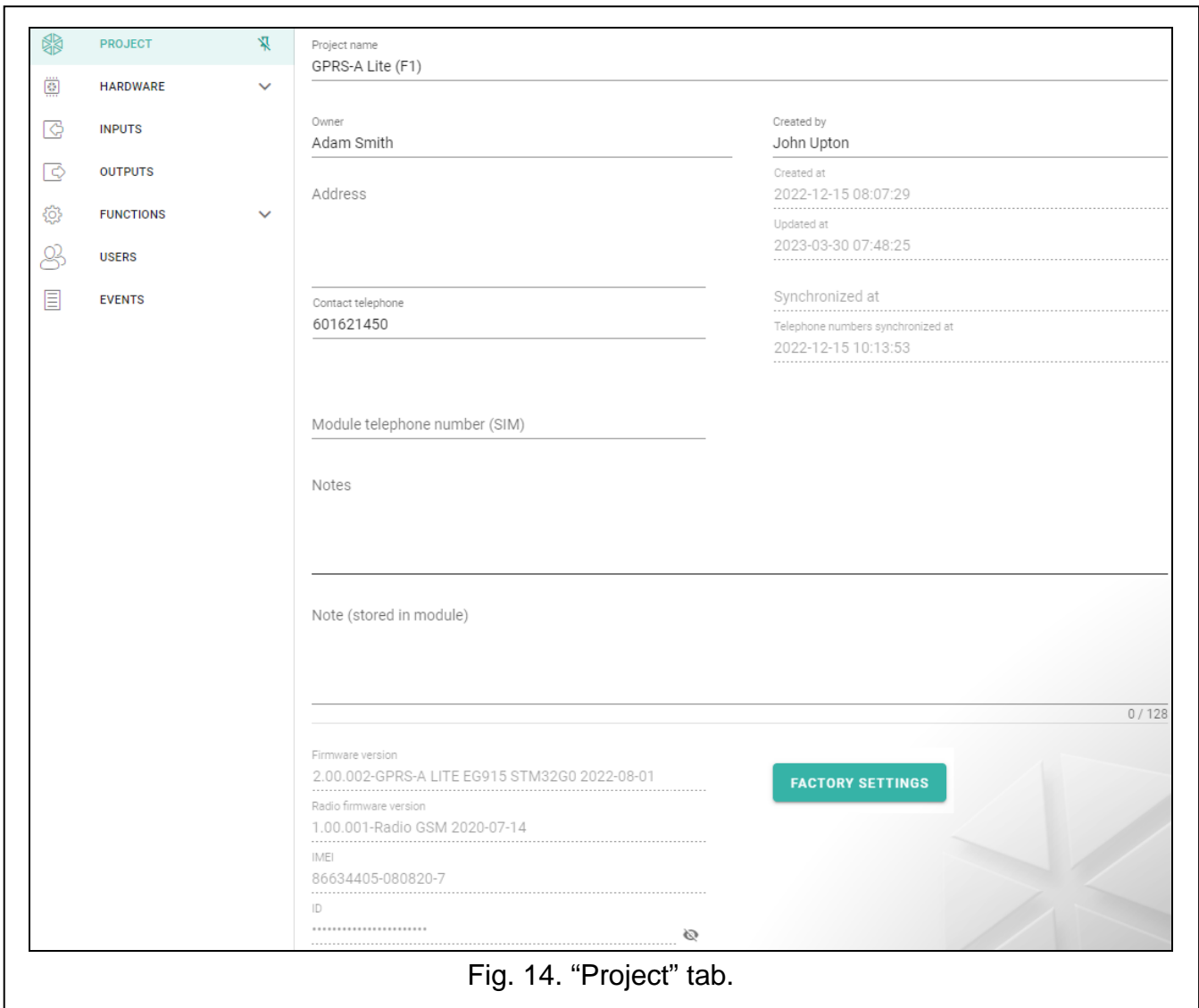

Fig. 14. "Project" tab.

## 6.4 Hardware

### 6.4.1 Mainboard

**Module language** – you can select the default language to be used for any descriptions in the module. The names of inputs, 1-Wire sensors, outputs, users and descriptions of events in the GX Soft program will be displayed in the language selected, regardless of the language version of the program (see "Settings" window" p. 15) and application.

**GSM signal problem delay** – the time after which the module will report any problem with the cellular signal (e.g. signal jamming / interference). You can program from 0 to 30 seconds. The delay is set to 15 seconds by default.

## Tel. numbers verification (SMS control and answer to CLIP)

**Users tel. numbers** – if this option is enabled, SMS control is possible from user telephones only (see “Users” p. 41). The module can also answer to CLIP from a user telephone.

**No verification** – if this option is enabled, the module can be controlled from any telephone. The module can also answer to CLIP from any telephone.

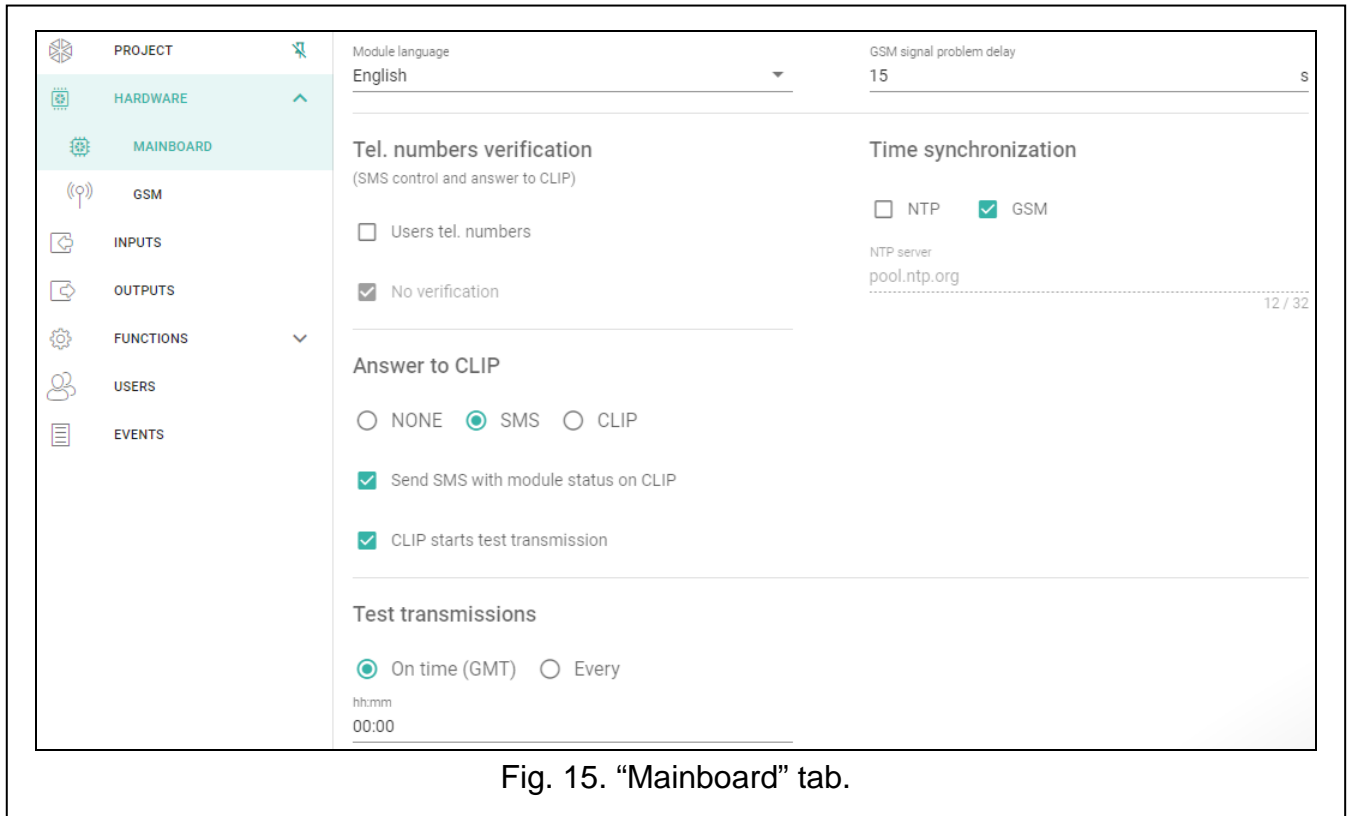

Fig. 15. “Mainboard” tab.

### Time synchronization



*The module uses the Greenwich Mean Time (GMT), not the local time (the time zones are not taken into account).*

**NTP** – if this option is enabled, the module clock is synchronized with the time server.

**GSM** – if this option is enabled, the module clock is synchronized with the time of the cellular network operator.

**NTP server** – time server address. The field is available if the “NTP” option is enabled. You can enter the IP address or domain name.

### Answer to CLIP

The module offers the CLIP answering feature. CLIP means calling without establishing connection (you must hang up on hearing the first ring signal), i.e. toll-free. The module will identify the phone number of the calling party and respond accordingly.

**NONE** – select this option if the module is not to answer to CLIP.

**SMS** – select this option if the module is to answer to CLIP using SMS message.

**CLIP** – select this option if the module is to answer to CLIP using CLIP.

**Send SMS with module status on CLIP** – if the option is enabled, in response to CLIP the module will send an SMS message with the module status information (see p. 43).



*If the “Send SMS with module status on CLIP” option is enabled, in response to CLIP the module will send an SMS with “GPRS-A CLIP” content.*

**CLIP starts test transmission** – if the option is enabled, CLIP will start a test transmission.

## Test transmissions

**On time (GMT)** – select this option if the test transmission is to be sent every day at a specified time. Define the hour and minute.

**Every** – select this option if the test transmission is to be sent at specified time intervals. Define every how many days, hours and minutes.

**i** *The module will send a test transmission if, when programming the module events distribution, you define the monitoring station to which a test transmission is to be sent (see “Module events distribution” p. 31).*

*If option “Send test transmissions using all paths” (p. 31) is enabled, the test transmission is sent using all transmission paths included in the list that defines the order of using transmission paths (see “Reporting priority” p. 31).*

## 6.4.2 GSM

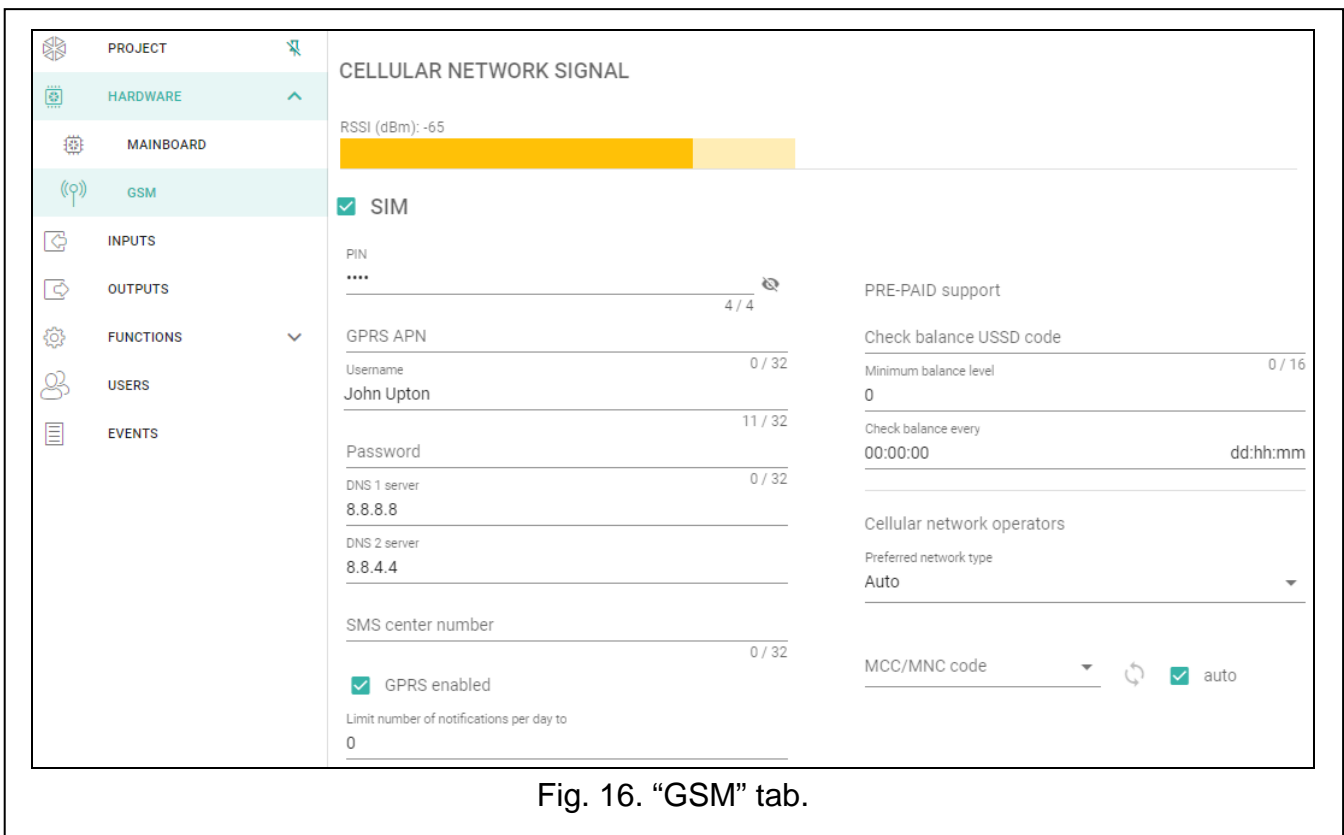

Fig. 16. “GSM” tab.

### CELLULAR NETWORK SIGNAL

**RSSI (dBm)** – indicator of received radio signal strength.

**SIM** – if this option is enabled, the SIM card is supported by the module. Disable the option, if the card is not to be used. Disabling the option will prevent unnecessary reporting of troubles related to that card.

**PIN** – PIN code of the SIM card. Click  to view the code.

**i** *If an incorrectly programmed PIN code is used, the module will report a trouble and will be waiting until the correct PIN code is entered.*

*Restarting the module with a wrongly programmed PIN code three times will block the SIM card. To unblock the SIM card, remove it and insert into a mobile phone. Then, enter the PUK code.*

**GPRS APN** – access point name for Internet connection.

**Username** – user name for Internet connection.

**Password** – password for Internet connection.

**DNS 1 server / DNS 2 server** – IP address of DNS server to be used by the module. It is recommended to program the IP address of DNS server. The IP address is necessary for sending data via cellular network, if the address of the device the module is to connect to (monitoring station, computer with GX Soft program) is entered as a name.



*The Internet connection settings you can obtain from the cellular network provider.*

**SMS center number** – telephone number of the short message service center. It is used as a connecting link when sending SMS messages. If the number has been saved by the operator to the SIM card memory, it need not be programmed. Otherwise, if the module is to send SMS messages, it must be entered. The number must be suitable for the operator of network in which the SIM card is registered.

**GPRS enabled** – enable this option if the data are to be sent via cellular network. If the option is disabled, sending data via cellular network is not available.

**Limit number of notifications per day to** – this field allows you to specify the maximum number of transmissions (GPRS/LTE, SMS, CLIP) made by the module during a day. Values from 0 to 255 can be entered. Entering 0 means no transmission limit (default: 0).

## PRE-PAID support

**Check balance USSD code** – the USSD code which is used to check balance of the SIM card account. If the code has been programmed, the module can check the SIM card account balance.

**Minimum balance level** – the minimum amount of funds on the SIM card account. If the amount of funds drops below the minimum level:

- trouble will be reported,
- where the SIM card account balance is checked automatically, information on the account balance will be sent as an SMS message to the phones of users for which the “Forward SMS” option is enabled (see “Users” p. 41).

**Check balance every** – the field defines every how many hours the module will perform the SIM card balance check. Entering 00:00 will disable the check.

## Cellular network operators

**Preferred network type** – the type of network to which the SIM card is to log in. You may leave the default setting “Auto” (the module’s telephone can connect to 2G or 4G network) or force the SIM card to connect only to a selected type of network (2G or 4G).

**MCC/MNC code** – codes of the operator of cellular network to which the SIM card is to log in. Enter in turn:

- MCC (Mobile Country Code) – country code,
- MNC (Mobile Network Code) – operator code.

Remember that entering invalid data may make logging into the cellular network impossible. Unless you enter the code, the module will log into the SIM card operator network (“auto” option disabled) or into the network offering the best signal (“auto” option enabled).



– click the button if you want to download the list of cellular network operators. When the list appears, select one of the available cellular network operators. The operator's codes will be entered automatically.

**auto** – if this option is enabled and the module cannot log into the cellular network of the operator defined by means of the MCC/MNC code, it will log into the available cellular network.

## 6.5 Inputs

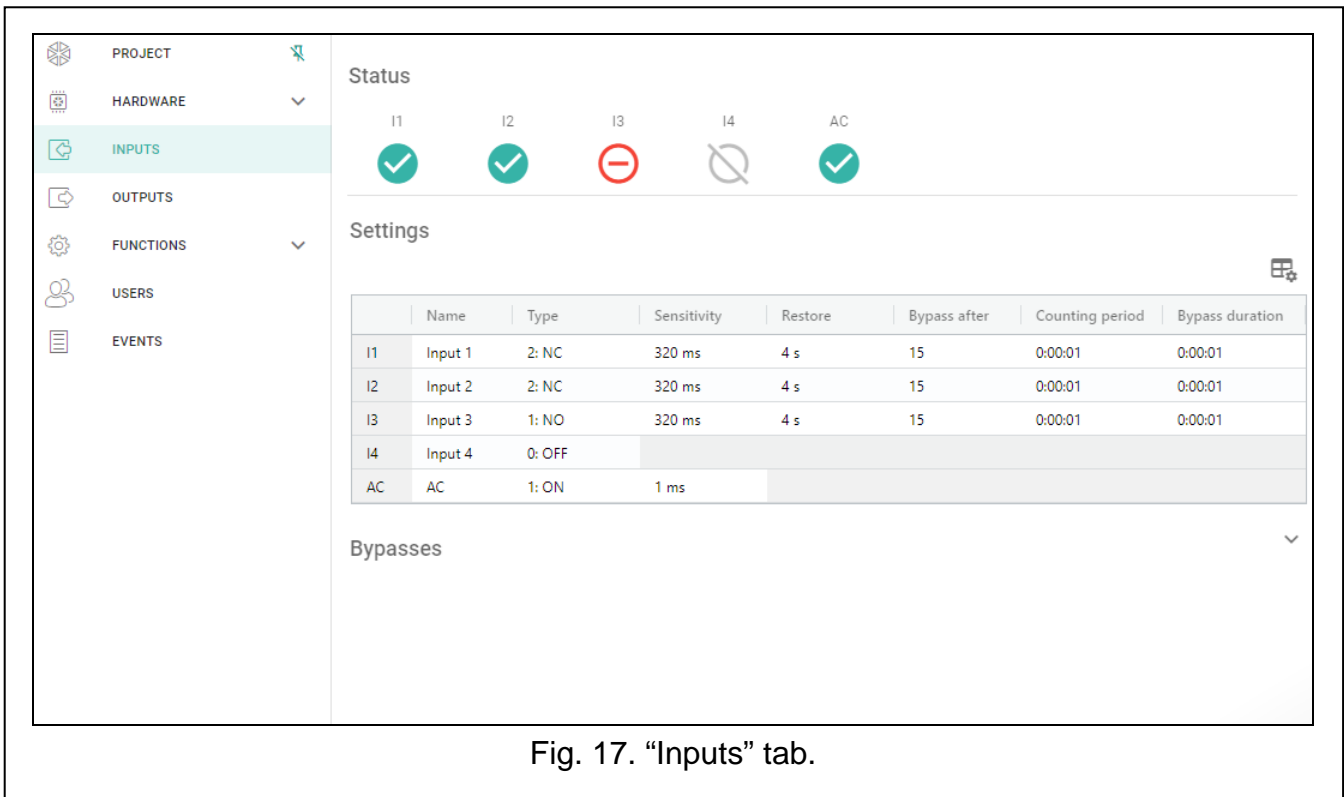







Fig. 17. "Inputs" tab.

### 6.5.1 Status

-  input not used. The "OFF" option is selected in the "Type" field (see: "Type" p. 22).
-  input in normal status (not violated). Click to bypass the input.
-  input violated. Click to bypass the input.
-  input bypassed. Click to unbypass the input.

The buttons are displayed when the program is connected to the module.

### 6.5.2 Settings

 – click to show the table options. The options enable you to hide / show the selected columns in the table and to fit the columns to its content or to the width of the window.

**Name** – individual name of the input (up to 16 characters).

**Type** – you can program the input as:

- OFF** – not used.
- ON** – used to supervise power supply (type only available for AC input).
- NC** – digital, normally closed.
- NO** – digital, normally open.

**Sensitivity** – time during which:

- the NC type digital input must be disconnected from the ground so that the module can register the input violation,



- the NO type digital input must be shorted to ground so that the module can register the input violation.

You can program from 20 to 5100 ms (every 20 ms).

**Restore** – time during which:

- the NC type digital input must be again shorted to ground so that the module can register input restore,
- the NO type digital input must be again disconnected from the ground so that the module can register input restore.

The defined time makes it possible to reduce the number of sent transmissions. You can program from 1 to 255 seconds.

**Bypass after** – the number of violations after which the input will be automatically bypassed (the input is bypassed after restore). You can program from 0 to 15. Value 0 means no bypass.

**Counting period** – the time after which the counter of violations for the given input will be reset. You can program from 0 to 24 hours. Value 0 means that the violations will be counted without time limits.

**Bypass duration** – if the input is to be automatically bypassed for a specific time period, enter the time here. You can program from 0 to 24 hours. Value 0 means that the given input will be bypassed until unbypassed by the user.

### 6.5.3 Bypasses



– click to show the table options. The options enable you to hide / show the selected columns in the table and to fit the columns to its content or to the width of the window.

You can indicate the input which, in the event of violation, will bypass other inputs of the module. When the input is restored, the bypassed inputs will be unbypassed. Each of the module inputs can bypass the other 3 inputs. The table line present the “Bypassing” inputs, and the columns present the “Bypassed” inputs. If you want the input violation to bypass another module input, select the field at the intersection of the corresponding line and column.

## 6.6 Outputs

---

### 6.6.1 Control



output inactive. Click to activate the output.



output active. Click to deactivate the output.

The buttons are displayed when the program is connected to the module.

### 6.6.2 Settings



– click to show the table options. The options enable you to hide / show the selected columns in the table and to fit the columns to its content or to the width of the window.

**Name** – individual name of the output (up to 16 characters).

**Operating time** – time during which the output is active. Entering “0” will keep the output in the same status until deactivated by the user.

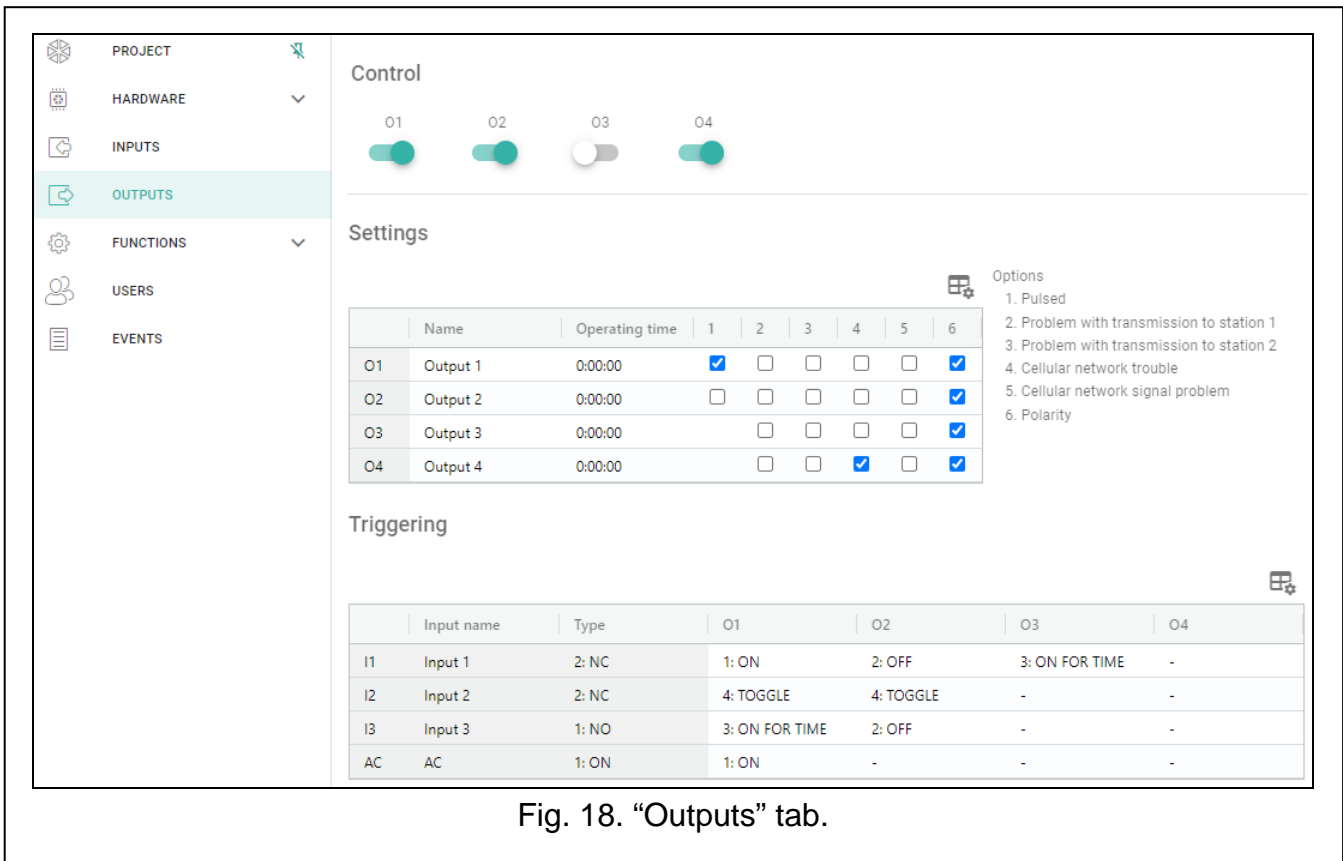

Fig. 18. "Outputs" tab.

**Options**

**Pulsed** – if this option is enabled, the output is pulsating when it is active.

**Problem with transmission to station 1 / 2** – if this option is enabled, the output will be active in the case of any problem with transmitting events to the monitoring station 1 / 2.

**Cellular network trouble** – if this option is enabled, the output is active in case of a problem with logging into the cellular network. The output will turn on about 2 minutes after a problem with logging into cellular network occurs, which may be caused by:

- missing SIM card,
- entering a wrong PIN code,
- missing or damaged antenna,
- unavailable cellular network (out of range),
- telephone damage.

**Cellular network signal problem** – if the option is enabled, the output is active in the case of any problem with the cellular signal (e.g. signal jamming / interference). The time during which the problem must occur for the output to be activated can be defined in the "Mainboard" tab (see: "GSM signal problem delay" p. 18).

**Polarity** – the option defines the operating mode of the output. If this option is disabled, the output is inverted.

	OC type output	
	option enabled (normal polarity)	option disabled (reverse polarity)
output inactive	disconnected from ground	shorted to ground
output active	shorted to ground	disconnected from ground

Table 1. Mode of OC type output operation depending on the "Polarity" option.

### 6.6.3 Triggering

 – click to show the table options. The options enable you to hide / show the selected columns in the table and to fit the columns to its content or to the width of the window.

You can define whether and how the inputs are to control the outputs. The table lines present the inputs, and the columns O1...O4 present the outputs of the module. If you want the input violation to change the output status, select one of the available options in the selection field at the intersection of the corresponding line and column:

-- input does not control the output.

1: **ON** – violation of the input will activate the output.

2: **OFF** – violation of the input will deactivate the output.

3: **ON FOR TIME** – violation of the input will activate the output for the time programmed in the “Operating time” field (see p. 23).

4: **TOGGLE** – violation of the input will switch the output to its opposite status.

5: **FOLLOW INPUT** – violation of the input will activate the output, and restoration of the input will deactivate the output.

 | *The table presents only those inputs that are in use.*

#### Inputs

The “Type” fields present information about the settings of inputs. For description of type, see sections “Inputs” (p. 22).

## 6.7 Communication

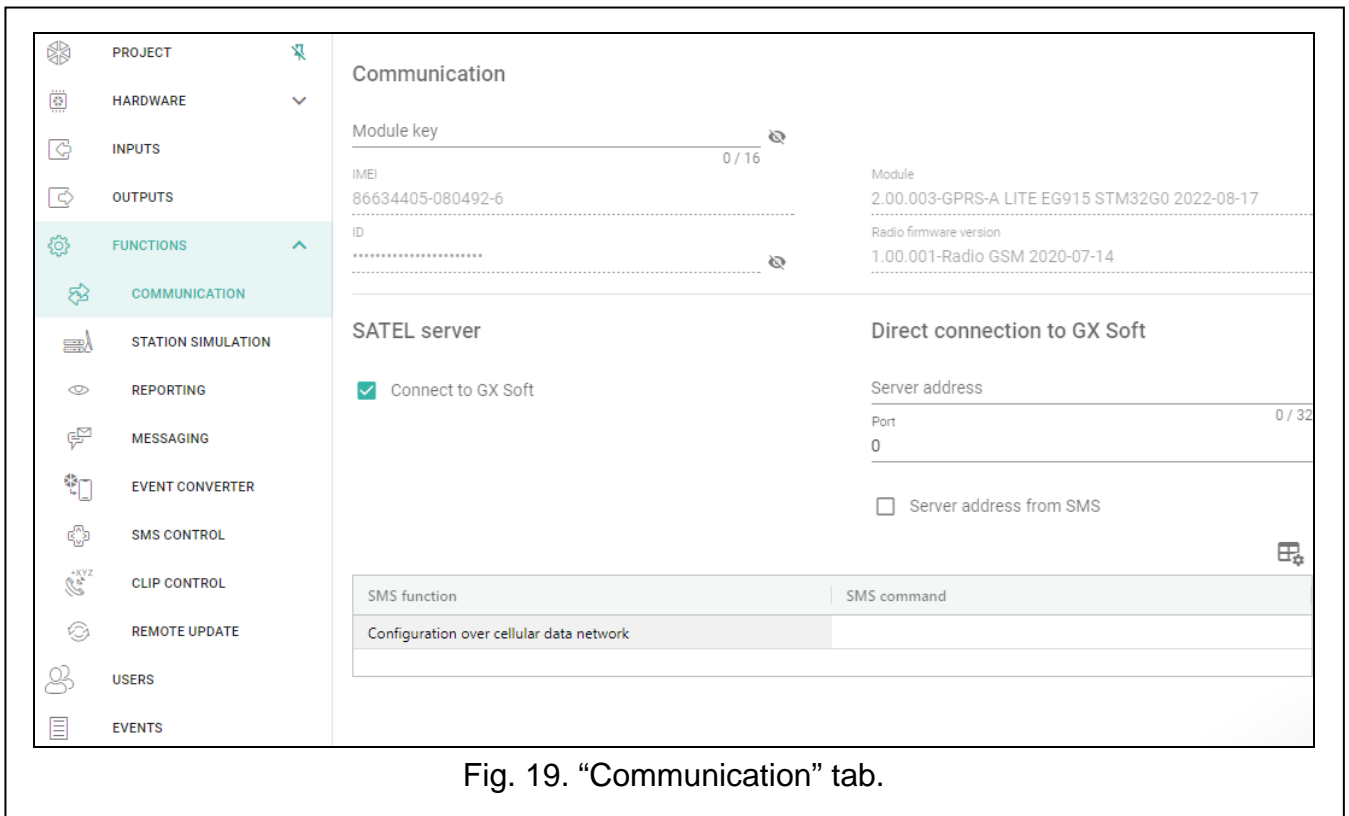



Fig. 19. “Communication” tab.

**Module key** – a string of characters for identification of the module. You can enter up to 16 alphanumeric characters (digits, letters and special characters). You can use spaces, but at least one character must be different from space. Do not program the same key for

different modules. Communication between the GX Soft program and the module is possible if the keys in the program and the module are identical. Click  to view the key.

**IMEI** – individual identification number of the module cellular telephone.

**ID** – individual identification number for the purposes of communication through the SATEL server (assigned automatically by the SATEL server). Click  to view the number.

**Module** – module firmware version: number and date of compilation.

**Radio firmware version** – version number of radio firmware.

### 6.7.1 SATEL server

**Connect to GX Soft** – if this option is enabled, it is possible to establish connection between the GX Soft program and the module through the SATEL server.



*Make sure that the SIM card tariff plan is suited to the requirements of communication via the SATEL server (connection to the server is active at all times).*

### 6.7.2 Direct connection to GX Soft

**Server address** – address of the computer running the GX Soft program. It must be a public address. You can enter the IP address or domain name.

**Port** – number of the TCP port used for direct communication between the module and the computer with GX Soft program. You can enter values from 0 to 65535 (0=disabled).

**Server address from SMS** – if this option is enabled, the address of server, to which the module is to connect, and the port number can be entered in the content of SMS message initiating the connection. If the address is not entered, the module will connect to the computer whose address has been programmed in the module.

**SMS function** – the function that is run on receiving the control message. The function enables direct connection between the module and the GX Soft program to be established via cellular network.

**SMS command** – the control command which, if sent in the SMS message, will initiate communication between the module and the GX Soft program. You can enter up to 16 alphanumeric characters except spaces (digits, letters and special characters).



*The command content must be different from that of the other control commands programmed in the module.*

*In the SMS message, you can include address of the computer the module is to connect to, and the number of TCP port which is to be used for communication.*

## 6.8 Station simulation

---

**Station simulation** – if this option is enabled, the module can receive event codes from a device connected to the telephone line output (the module simulates the monitoring station).

**Events buffering** – if this option is enabled, each event received by the module from the control panel is written to the module event log and confirmed immediately on receipt. If the option is disabled, events from the control panel will not be written to the module event log, and the received event will only be confirmed after the module receives acknowledgement of the event receipt by the monitoring station.

**No voltage on TIP/RING if GSM trouble** – if this option is enabled, voltage on the telephone line terminals will be turned off in case of the cellular telephone trouble.

**Station 1 (ST1) / Station 2 (ST2)**

**Reporting format** – format in which event codes are sent to the monitoring station.

The following formats are supported: SIA, CID, AdemcoExpress, Sil.Knight/Ademco slow, Radionics 1400Hz, Radionics 1400Hz with parity.

**Obtain identifier automatically** – enable this option, if the control panel identifier is to be used by the module for module's own test transmissions. Enabling this option is not recommended when several identifiers are used by the control panel for reporting purposes (when sending a code of module related event, the identifier used last time by the control panel will be used, which means that events related to the module can be sent with different identifiers).

**Replace obtained identifier** – enable this option, if the module, after receiving the event code from the control panel and before sending it to the monitoring station, is to replace the identifier in event code with characters programmed in the “Module identifier” field (see “Reporting” tab p. 29).

**Station tel. number** – if this number is dialed by the device connected to the telephone line output, the module will be receiving the event codes. If the “Reporting” option (p. 28) is enabled in the module, the received codes can be retransmitted by the module to the monitoring station. Define how they should be sent – see “Reporting priority” p. 31.



*The programmed number must be unique and must not coincide with any other number programmed in the module.*

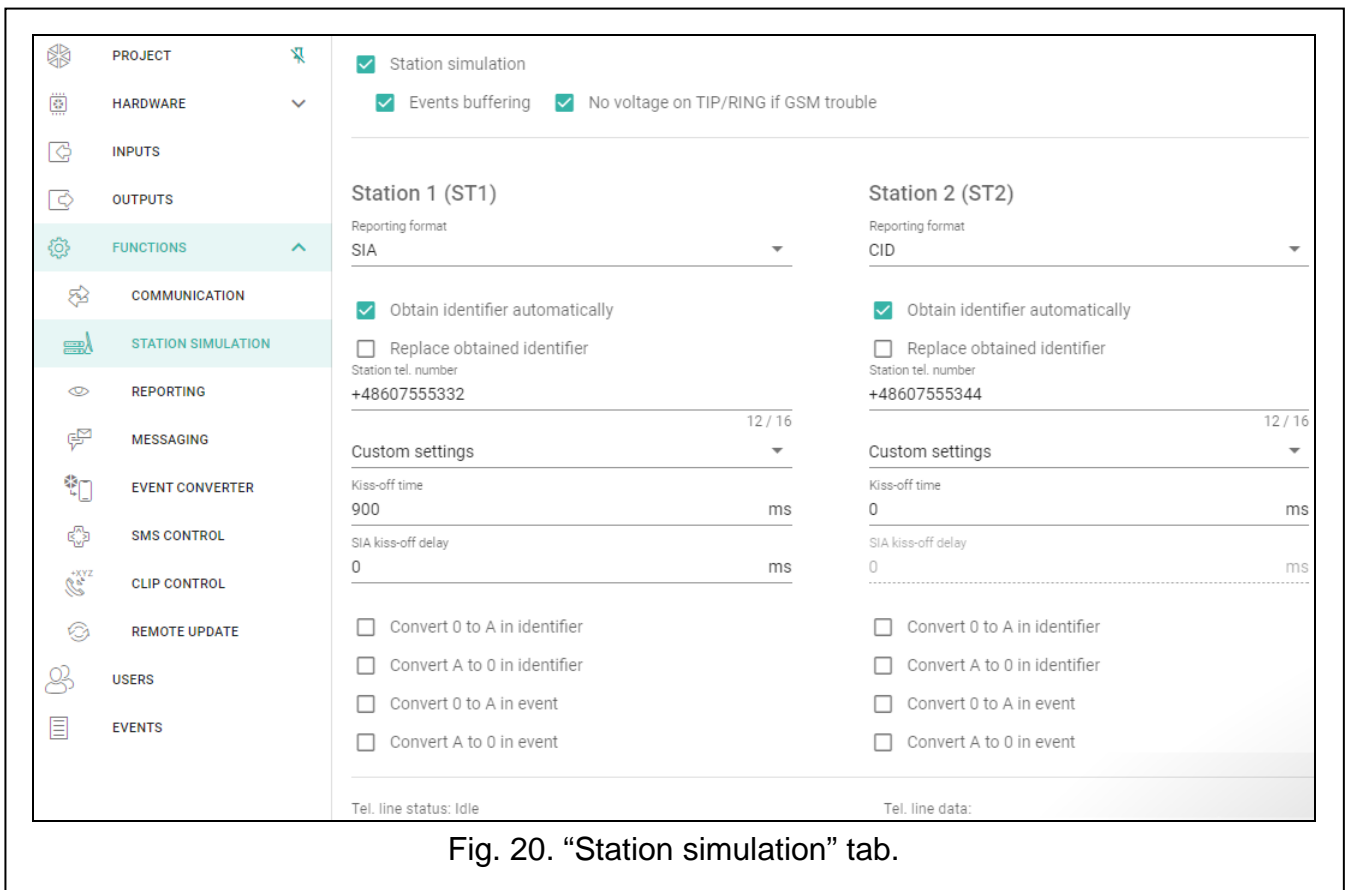

Fig. 20. “Station simulation” tab.

**[Kiss-off]** – the way of setting the “Kiss-off time” and “SIA kiss-off delay” parameters.

**Custom settings** – you can configure the parameters manually.

**Typical settings** – the parameters are configured automatically, as required by the selected reporting format (“Reporting format”).

**[control panel]** – the parameters are configured automatically, as required by the selected alarm control panel.

**Kiss-off time** – duration of the signal generated by the module to confirm receipt of the event from the control panel. The value entered must be suitable for the reporting format selected in the control panel. You can program from 0 to 9999 ms (default: 0 ms). Programming value 0 means that the kiss-off time will be programmed according to the standard of the format selected in the control panel.

**SIA kiss-off delay** – the time by which the acknowledgment of receipt by the module of the event in SIA format will be delayed. The value entered must be suitable for the control panel settings. You can program from 0 to 9999 ms (default: 0 ms). Programming value 0 means that the time of kiss-off delay will be programmed according to the SIA format standard.

## Conversion

For events in Ademco Express and Contact ID format, you can select the following options:

**Convert 0 to A in identifier** – if this option is enabled, the module will convert 0 into A in the identifier of event sent to the monitoring station.

**Convert A to 0 in identifier** – if this option is enabled, the module will convert A into 0 in the identifier of event sent to the monitoring station.

**Convert 0 to A in event** – if this option is enabled, the module will convert 0 into A in the code of event sent to the monitoring station.

**Convert A to 0 in event** – if this option is enabled, the module will convert A into 0 in the code of event sent to the monitoring station.

## Information

**Tel. line status** – information about current handling of the telephone line output.

**Tel. line data** – information about the data currently being received from the device connected to the telephone line output.

## 6.9 Reporting

---

The module can send event codes to the monitoring station by using the following transmission paths:

- GPRS/LTE,
- SMS messages (module gets no acknowledgement of event code receipt).



*If the “Events buffering” option is not enabled, events received by the module from the control panel have a priority over events generated by the module and their codes are sent to the monitoring station first.*

**Reporting** – if the option is enabled, the module can send event codes to the monitoring station. The option applies to the events received by the module from the alarm control panel and the events generated by the module.

**Reporting mode** – the way of sending event codes to the monitoring stations:

**Only Station 1** – the event codes are only sent to station 1.

**Only Station 2** – the event codes are only sent to station 2.

**Station 1 and Station 2** – the event codes are sent to both stations (the module must receive acknowledgement of the receipt of the code from both monitoring stations).

**Station 1 or Station 2** – the module will make an attempt to send the event code to station 1 and, if unsuccessful, to station 2.

**Station 2 takes over link test from station 1** – if this option is enabled when the module fails to connect to the monitoring station 1 during the link test, the module will test link to the monitoring station 2. The option can be enabled if the SIA-IP format is selected for both monitoring stations in the “IP format / protocol” field (see p. 29).

## Station 1 (ST1) / Station 2 (ST2)

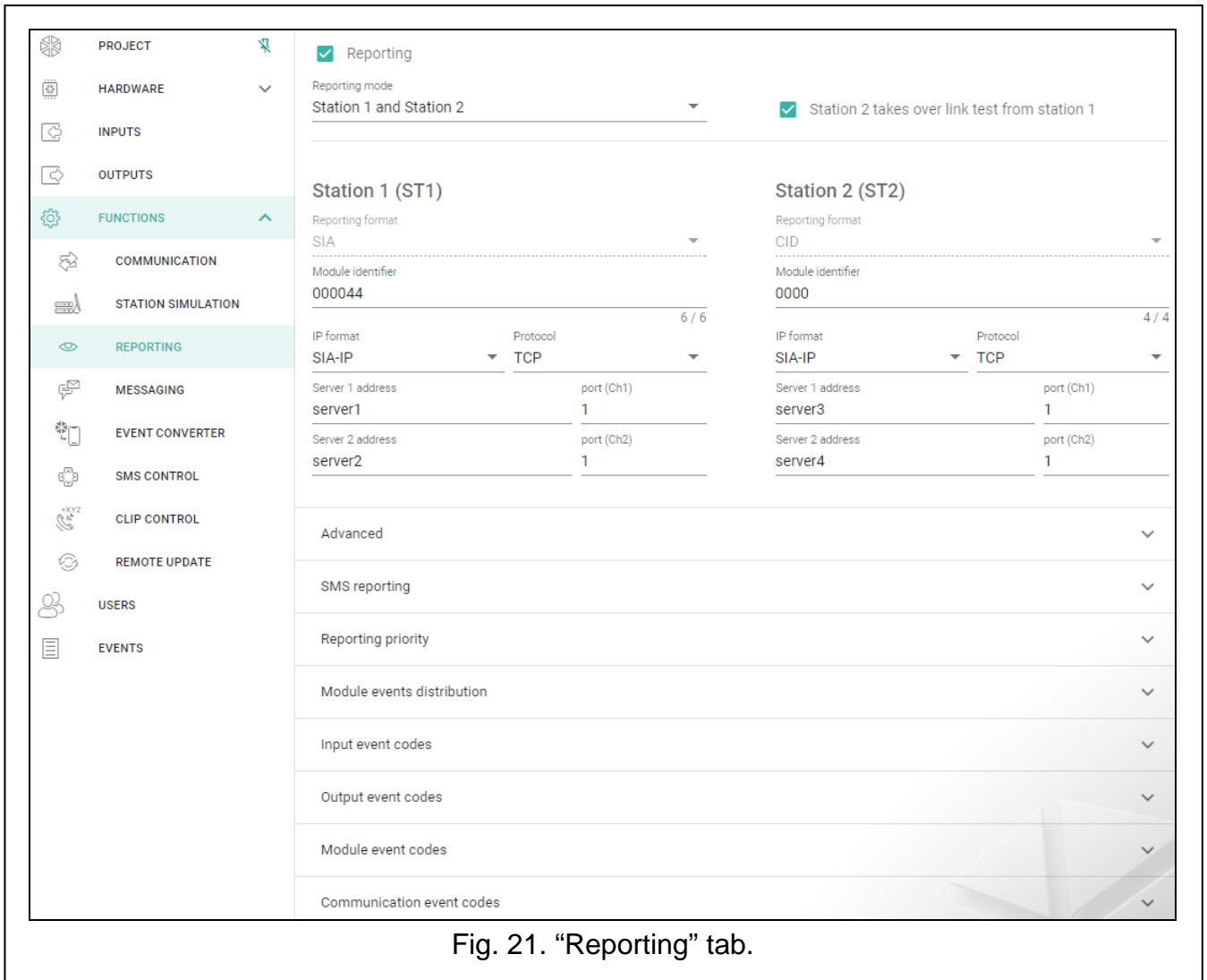

Fig. 21. “Reporting” tab.

**Reporting format** – the format in which event codes are sent to the monitoring station. The following formats are available: SIA, CID, AdemcoExpress, Sil.Knight/Ademco slow, Radionics 1400Hz, Radionics 1400Hz with parity. If the “Station simulation” option (p. 26) is enabled in the module, the field cannot be edited. If this is the case, information about the format selected in the “Station simulation” tab (see “Reporting format” p. 27) is displayed in the field. If “AdemcoExpress”, “Sil.Knight/Ademco slow”, “Radionics 1400Hz” or “Radionics 1400Hz with parity” format is selected, information that the codes are sent in 4/2 format is displayed.

**Module identifier** – a string of characters that enables the monitoring station to define from where the events are being sent. For the Contact ID format, it consists of 4 hexadecimal characters (digits or letters from A to F). For the SIA format, it consists of 6 hexadecimal characters (digits or letters from A to F).

**IP format / Protocol** – for reporting via cellular network, you must define:

- format: SATEL or SIA-IP (SIA DC-09 standard).
- protocol: TCP or UDP.

**Server 1/2 address / port (Ch1)/(Ch2)** – in the case of reporting via cellular network, enter:

- address of the monitoring station. You can enter either the IP address or the domain name.
- number of the port used for communication between the module and the monitoring station during reporting. You can enter a value from 0 to 65535.

## Advanced

**SATEL station key** – a sequence of characters for encrypting data sent in SATEL format to the monitoring station via cellular network. You can enter up to 12 alphanumeric characters (digits, letters and special characters). If you want to enter 24 hexadecimal characters (digits or letters from A to F), enable the “hex” option.

**ETHM/GPRS key** – a string of characters, which is used to identify the module for the purpose of reporting via cellular network in SATEL format. You can enter up to 5 alphanumeric characters (digits, letters and special characters). If you want to enter 10 hexadecimal characters (digits or letters from A to F), enable the “hex” option.

**SIA-IP account number** – a string of characters, which is used to identify the module for the purpose of reporting in SIA-IP format. You can enter up to 16 hexadecimal characters (digits or letters from A to F).

**SIA-IP key** – a sequence of characters for encrypting data sent in the SIA-IP format. You can enter up to 16 alphanumeric characters (digits, letters and special characters). If you want to enter 32 hexadecimal characters (digits or letters from A to F), enable the “hex” option.

**Account prefix (L) / Receiver number (R)** – a string of characters used to identify the module for the purpose of reporting in SIA-IP format. The parameters enable you to expand the list of attributes used to identify the module. You can enter up to 6 hexadecimal characters (digits or letters from A to F).

**Both servers link test** – if this option is enabled, the module will test link to the two servers of the monitoring station. The option applies to SIA-IP format.

**Supervision every** – in the case of reporting in the SIA-IP format, an additional transmission can be sent at specified intervals to check link with the monitoring station. You can program a number of days, hours, minutes and seconds between the transmissions. Entering zeros only means that no additional transmission will be sent.

**Server 2 takes over link test from server 1** – if this option is enabled when the module fails to connect to the monitoring station server 1 during the link test, the module will test link to the server 2 (according to settings provided for testing the server 1). The option applies to SIA-IP format.

**Transmission period acc. to** – the way of setting the “Supervision every (Server 1)” and “Supervision every (Server 2)” parameters.

**DP1 / DP2 / DP3 / DP4** – the parameters are configured automatically, as required by the EN 50136-1 standard for Dual Path Reporting.

**OTHER** – you can configure the parameters manually.

The options are available when the “Both servers link test” option is enabled.

**Supervision every (Server 1) / Supervision every (Server 2)** – number of days, hours, minutes and seconds between the tests of link to servers. The fields are displayed when the “Both servers link test” option is enabled.

### *SIA-IP options*

**Encrypt** – if the option is enabled, the data being sent are encrypted, and additionally the date and time are sent with event code (the monitoring station can program the date and time in the module).

**Send timestamp** – if the option is enabled, the date and time are sent with event code (the monitoring station can program the date and time in the module). It is available, when the “Encrypt” option is disabled.

## SMS reporting

**SMS reporting – tel. number** – phone number of the monitoring station for SMS reporting.



**SMS format** – SMS format for SMS reporting. It must be defined as required by the monitoring station. The SMS message format, preset by default in the module, corresponds to the default settings of the STAM-2 monitoring station (firmware version 1.2.0 or newer) for the Contact ID format.



*The STAM-2 station and SMET-256 converter do not support SMS messages in SIA format. The form of SMS message sent by the module in SIA format is #ID|CODE, where ID is 4- or 6-character identifier, and CODE is the received event code.*

## Reporting priority

**Reporting priority** – if sending an event code to the monitoring station using one transmission path fails, the module can use another transmission path. You must specify the order of using different transmission paths by the module. A successful send of the event code to the monitoring station will terminate the procedure (except for the test transmissions if option “Send test transmissions using all paths” is enabled). For each transmission path, you can define:

**Ch1 / Ch2** – if the option is enabled, the module will try to send the event code to the address of the given server. If you select sending to the two addresses, a successful send of event code to the first address will terminate the procedure. An exception is the test transmission if option “Send test transmissions using all paths” is enabled. In such case the module will try to send the event code to both servers.

**Timeout** – the maximum time during which the module will try to send the event code to selected addresses. If the event code is not sent during that time, the module will switch over to the next address, and then to the next path on the list.

**Suspend time** – the time for which reporting will be suspended, if attempts fail to send an event code through all provided transmission paths. The module will resume the attempt of establishing connection with the monitoring station after this time expires or a next, new event occurs. Up to 30 minutes can be programmed (by default: 1).

**Number of retries** – the number of unsuccessful retries to send the event over the given reporting path, after which the module will make an attempt to send the event over the next path. You can program from 1 to 100 (by default: 3).



*The module will only use the transmission paths for which priority is specified (they are included in the list defining the order of using transmission paths).*

*In the case of SMS reporting, the module gets no acknowledgement of receiving the event codes by the monitoring station, hence this transmission path should be used as the last one.*

**Send test transmissions using all paths** – if the option is enabled, test transmission will be sent using all paths for which priority is specified (they are included in the list defining the order of using transmission paths). If the option is disabled, a successful send of event code to the monitoring station using one of the paths will terminate the procedure.

## Module events distribution

Define which events are to be sent to the monitoring station 1 and which to the monitoring station 2. The code of a module related event will be sent to the monitoring station only when the box corresponding to the given event is checked. Adjust the distribution of events to the way of sending codes, selected in the “Reporting mode” field (see p. 28).

## Event codes



– click to show the table options. The options enable you to hide / show the selected columns in the table and to fit the columns to its content or to the width of the window.

For each event generated by the module, you can define codes in three formats:

**4/2** [Ademco Express, Sil.Knight/Ademco slow, Radionics 1400Hz, Radionics 1400Hz with parity] – enter 2 characters (digits or letters from A to F). The event code must be consistent with the code programmed for the event in the monitoring station.

**SIA** – enter event code consistent with SIA format by using the code editor. To open the code editor, click .

**Contact ID** – enter event code consistent with CID format by using the code editor. To open the code editor, click .

## 6.10 Messaging

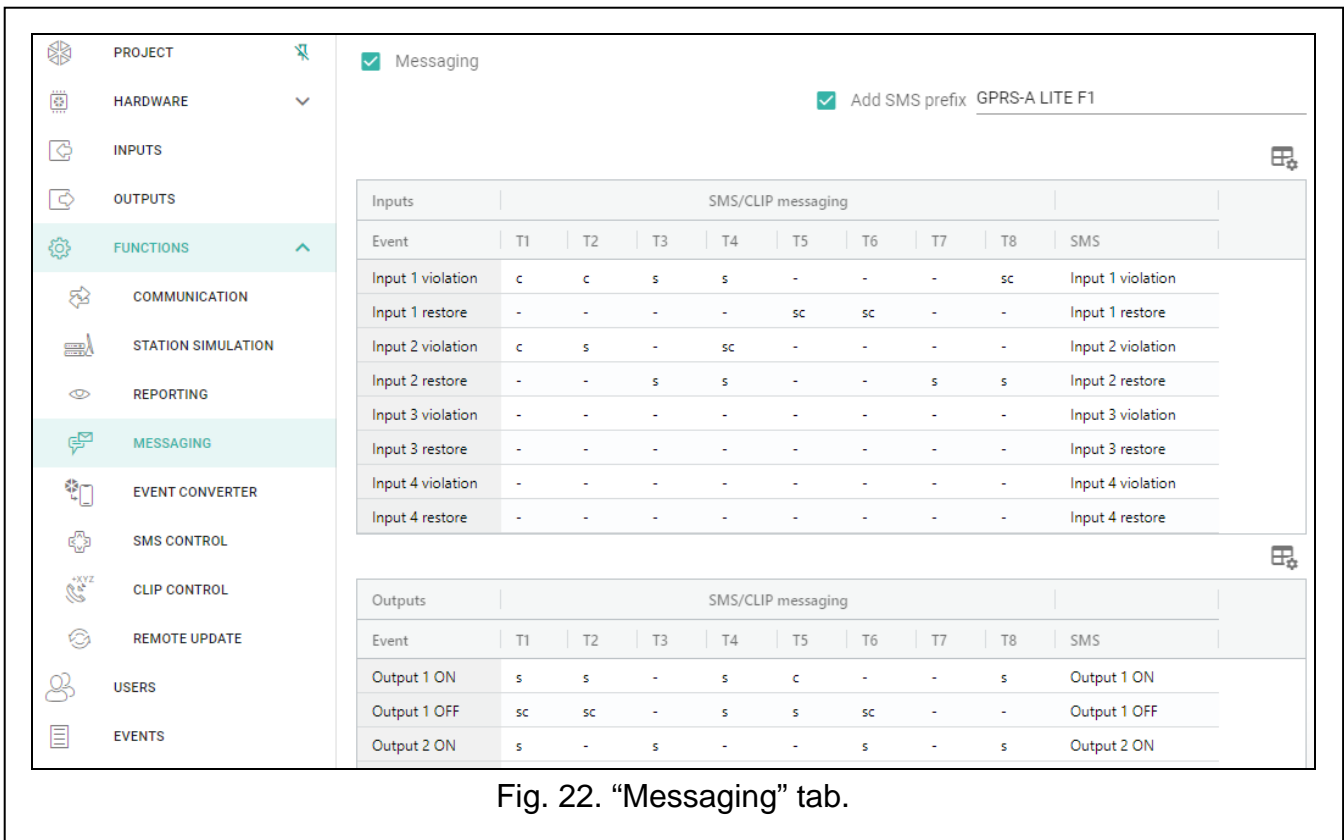



Fig. 22. "Messaging" tab.

The module can send notifications about events by means of:

- **SMS messages** – the content of the messages which are to be used for notification should be saved to the module by using the GX Soft program.
- **CLIP** – the module provides information about event by calling the programmed phone numbers and hanging up automatically after maximum 15 seconds. CLIP provides toll-free messaging capability. The displayed module telephone number should be treated as a notification of event.

**Messaging** – if this option is enabled, the module can send notifications of module related events.

**Add SMS prefix** – if this option is enabled, you can define in the adjacent field a prefix to precede the body of messages sent by the module in the SMS notifications. The prefix can contain up to 32 characters (digits, letters and special characters).

 *If the entire message (body plus prefix) consists of more than 32 characters, the prefix will not be added to the message.*

## Inputs / outputs



– click to show the table options. The options enable you to hide / show the selected columns in the table and to fit the columns to its content or to the width of the window.

### [Other]



– click to show the table options. The options enable you to hide / show the selected columns in the table and to fit the columns to its content or to the width of the window.

**Test transmission with module status** – if this option is enabled, module status information is sent in SMS message to notify of the “Test transmission” event.

### SMS/CLIP messaging

**Event** – event description.

**T1...T8** – you can select a messaging method for the given telephone (see “Users” p. 41):

- 0:** - - no messaging,
- 1: CLIP** – CLIP messaging [c],
- 2: SMS** – SMS messaging [s],
- 3: SMS, CLIP** – SMS and CLIP messaging [sc].

Click on the field and enter a digit from 0 to 3 or select the messaging method from the list.

**SMS** – content of the SMS message. The message may contain up to 32 characters.

### CLIP messaging



– click to show the table options. The options enable you to hide / show the selected columns in the table and to fit the columns to its content or to the width of the window.

**User** – user name (see “Users” p. 41).

**Attempts** – the number of attempts to send notification by means of CLIP to the given user telephone (see “Users” p. 41). You can enter from 0 to 15 (by default: 3).



*If the “Confirmation” option is disabled, the module will make just one call, regardless of the programmed number of attempts.*

**Confirmation – CLIP** – if this option is enabled, receipt of the CLIP message by the given user is to be acknowledged. In order to acknowledge receiving the message, the connection with module must be rejected not earlier than 10 seconds and not later than 20 seconds since the telephone ring is heard. Acknowledgement of receiving the CLIP messaging will make the module stop repeating it.

**SMS** – if this option is enabled, failure to receive the acknowledgement of CLIP messaging will result in sending to the given user telephone number of an SMS message with content entered for this event.

## 6.11 Event converter

---

The module can notify the users of events received from the control panel. Notifications can be realized via:

- SMS messages – the text of messages to be used for notification must be programmed.
- CLIP – the module will inform the users of the event by calling the programmed phone numbers and disconnecting automatically after maximum 15 seconds. CLIP offers toll-free notification. The displayed module telephone number is to be treated as event notification.

You can indicate 32 events of which the module will notify the users.

**Event converter** – if this option is enabled, the module can notify the users of the events received from the control panel.

**Add event details to SMS** – if this option is enabled, the number of partition where the event occurred and the number of user or the number of zone that caused the event will be automatically added to the SMS message sent by the module after receiving the event code. The option only applies to event codes in Contact ID format.

 – click to show the table options. The options enable you to hide / show the selected columns in the table and to fit the columns to its content or to the width of the window.

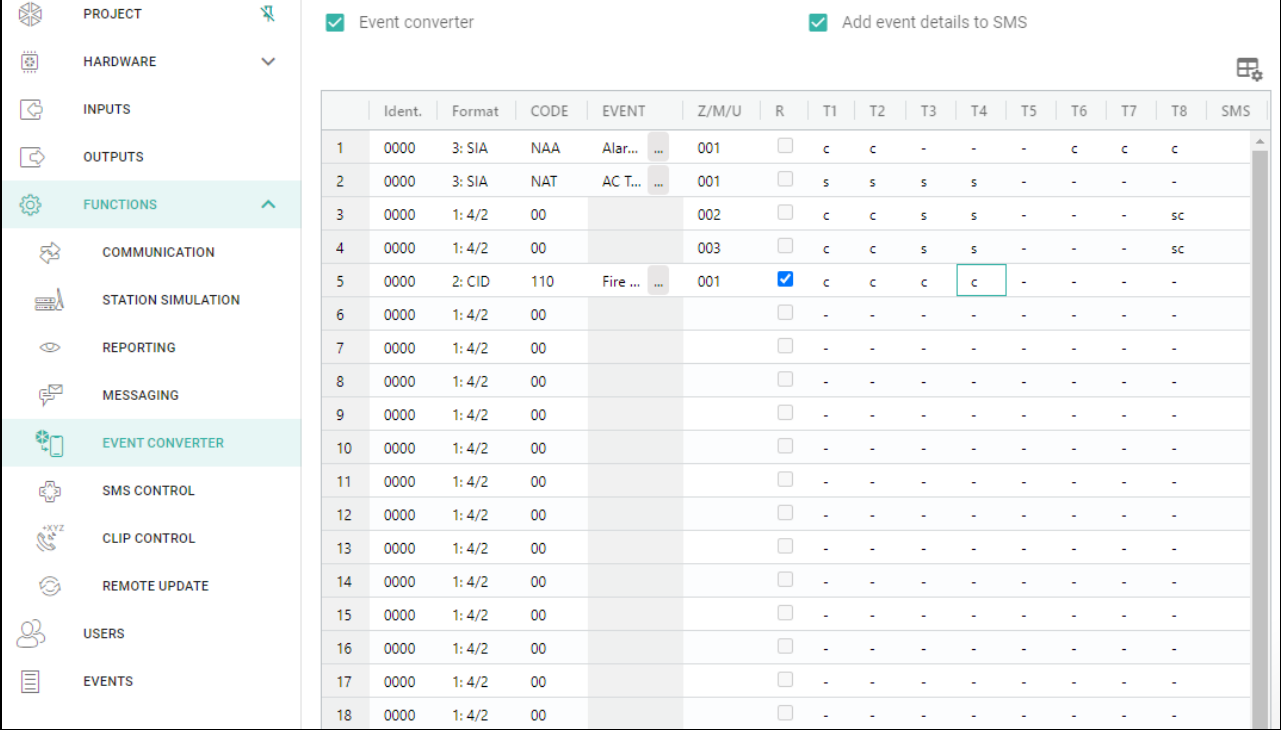



Fig. 23. "Event converter" tab.

**Ident.** – identifier that must precede the event code so that the module can send notification of the event. For 4/2 or Contact ID format, you can enter 4 characters (digits or letters from A to F). For SIA format, you can enter 6 characters. If you program no identifier, regardless of what kind of identifier is to precede the event code, receiving it will result in sending the message.

**Format** – format in which the event code must be received so that the module can send notification of the event. You can select: 1: 4/2, 2: CID or 3: SIA. Click on the field and enter a digit from 1 to 3 or select the format from the list.

**CODE** – event code, after receiving of which notification of the event will be sent. For 4/2 format, enter 2 characters (digits or letters from A to F). For Contact ID or SIA format, you can use the code editor. To open the code editor window, click the  button available in the "Event" field.

**EVENT** – event description. The field refers to SIA and Contact ID formats. It is autocompleted after entering the event code into the "CODE" field.

**Z/M/U** – number of zone / module / user that must be included in the received code so that the module can send notification of the event. The field applies to SIA and Contact ID formats.

**R** – the option applies to Contact ID format. If it is enabled, the received event code refers to event restore / arming. If it is disabled, the received event code refers to a new event.

**T1...T8** – you can select a messaging method for the given telephone (see "Users" p. 41):

**0:** - - no messaging,

- 1: **CLIP** – CLIP messaging [c],
- 2: **SMS** – SMS messaging [s],
- 3: **SMS, CLIP** – SMS and CLIP messaging [sc].

Click on the field and enter a digit from 0 to 3 or select the messaging method from the list.

**SMS** – the contents of SMS message which will be sent after receiving the selected event code. The message may be composed of up to 32 characters.

## 6.12 SMS control

You can control the module via SMS messages containing appropriate control commands.

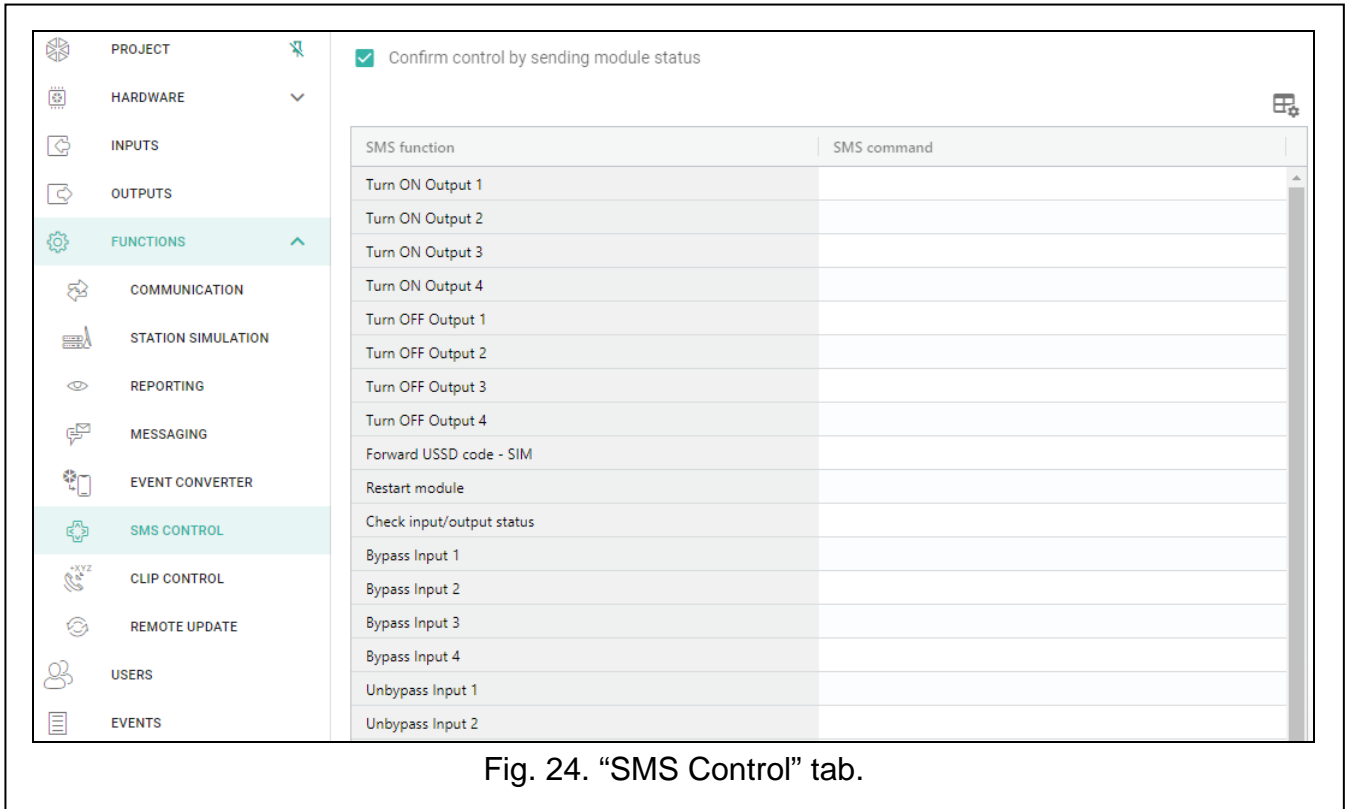

Fig. 24. “SMS Control” tab.

**Confirm control by sending module status** – if this option is enabled, after receiving an SMS message with control command, the module will confirm the receipt by sending a return SMS message with the module status.

– click to show the table options. The options enable you to hide / show the selected columns in the table and to fit the columns to its content or to the width of the window.

**SMS function** – function run on receiving the control command.

*The content of control commands must vary.*  
*The content of one control command must not be inserted into the content of another command.*

**SMS command** – the control command which, if sent in the SMS message, will run the function assigned to the command. You can enter up to 16 alphanumeric characters except spaces (digits, letters and special characters). For some functions, the SMS message sent must have a specified form:

**Forward USSD code – SIM** – allows you e.g. to check the account balance of SIM card installed in the module. The SMS message sent to the module must have the following form: “**xxxxxx=yyyy.**” or “**xxxxxx=yyyy=**”, where: “xxxxxx” – control command, “yyyy” – USSD code supported by the cellular network operator. The module will use the USSD

code contained in the command and will send the reply received from the operator to the telephone number from which the control command was sent.



*It is not advisable to use the advanced functions available due to the USSD service if menu is presented in response to the entered code.*

*The control command for sending USSD codes can be used for sending SMS messages through the module. The SMS message sent to the module must have the following form: "xxxxxx=telephone:text=", where "xxxxxx" – control command, "telephone" – telephone number to which the SMS message will be sent by the module, "text" – content of the message.*

**Change test transmission period** – allows you to program the interval after which a test transmission will be sent. The SMS message sent to the module must have the following form: "xxxxxx=M=" or "xxxxxx=H:M=", where: "xxxxxx" – control command, "M" – number of minutes after which the transmission will always be sent, "H:M" – hour and minute when the transmission will be sent once a day (enter Greenwich Mean Time (GMT)).

**Change user 1...8 tel** – allows you to program the number of telephone user. The SMS message sent to the module must have the following form: "xxxxxx=yyyy." or "xxxxxx=yyyy=", where: "xxxxxx" – control command, "yyyy" – new number of telephone user. It is recommended that the telephone number be preceded by the country code.

### Programming a list of additional telephones for CLIP control

By sending the SMS commands, you can configure a list of 10 thousand additional telephones from which control of the module outputs will be possible by means of the CLIP service.



*You can also configure the list in the "CLIP control" tab (see "Additional telephone numbers (configurable via SMS)").*

**Add CLIP number** – control command that allows you to add a telephone to the list and define how the module outputs will be controlled by CLIP from this number. The SMS message sent to the module must have the following form:

"xxxxxx=Description/Telephone/a/b/c/d=", where:

**xxxxxx** – control command.

**Description** – telephone description. Can contain up to 32 characters (digits, "." and "," characters, lower- and uppercase letters without diacritical marks). The module is case sensitive.

**Telephone** – telephone number from which control of the outputs will be possible by means of CLIP. You can provide the whole telephone number (including the country code) or only part of it. Up to five characters (consecutive digits from any part of the number, including "+") will be treated as part of the number. Six and more characters will be interpreted by the module as the whole telephone number.

**a/b/c/d** – the way of controlling the module outputs by means of CLIP (a – output O1; b – output O2, c – output O3, d – output O4). For each output, enter one of the digits:

**0** – CLIP does not control the output.

**1** – CLIP will turn on the output.

**2** – CLIP will turn off the output.

**3** – CLIP will turn on the output for a specified period of time (see "Operating time" parameter p. 23).

**4** – CLIP will switch the output to its opposite status.

If several different responses to CLIP from one telephone number are programmed for the given output (e.g. O1) (when you provide the number or part of it to several items on the list), then in response to CLIP from that number the output will be switched over successively to each of the configured statuses. The switching sequence will correspond to the consecutive numbers from the telephone list.

The execution of the command is not confirmed by the module.

**Remove CLIP number** – control command that allows you to remove a selected telephone from the list. The SMS message sent to the module must have the following form:

“**xxxxxx=Description=**” or “**xxxxxx=Telephone=**”, where:

**xxxxxx** – control command.

**Description** – description of the telephone to be removed. The whole description must be provided.

**Telephone** – number of the telephone to be removed. The whole number must be provided.

The execution of the command is not confirmed by the module.

**Check CLIP number** – control command that allows you to obtain information about selected telephones. The SMS message sent to the module must have the following form:

“**xxxxxx=Description=**” or “**xxxxxx=Telephone=**”, where:

**xxxxxx** – control command.

**Description** – description of the telephone(s) or part of it.

**Telephone** – number of the telephone(s) or part of it.

In response, the module will send an SMS with a list of telephones that meet the criteria defined in the SMS message. The amount of information is limited by the character limit for a single SMS message.

**Check CLIP numbers status** – control command that allows you to check how many telephones there are on the list. Send an SMS message containing this command, and in response you will receive an SMS saying: “CLIPSTATUS: X/10000”, where: X is the number of telephones configured and 10000 is the maximum number of telephones.

**Clear CLIP number list** – control command that allows you to delete all telephones from the list. The execution of the command is not confirmed by the module.

## 6.13 CLIP control

---

You can control the module outputs by using the CLIP service.

### Any telephone

You can program how the module outputs are to be controlled by using the CLIP service from any phone number.



*The numbers from the “Additional telephone numbers” list and the users' telephone numbers are not treated by the module as any telephone numbers.*

### Users

You can program how the module outputs are to be controlled by using the CLIP from the users' telephones (see “Users” p. 41).

### Additional telephone numbers

You can program how the module outputs are to be controlled by using the CLIP from additional phone numbers.

The search field is displayed above the table. If you want to find a telephone number:

1. Click on the search field and enter a string of characters included in the telephone number or its description.
2. Click . The telephone numbers that meet the search criteria will be displayed.

*If you want to display all telephone numbers, click in the search field (this will clear all the characters entered in the field).*

– click to import the telephone numbers from the file.

– click to export the telephone numbers to the file.

– click to delete the selected telephone numbers.

– click to show the table options. The options enable you to hide / show the selected columns in the table and to fit the columns to its content or to the width of the window.

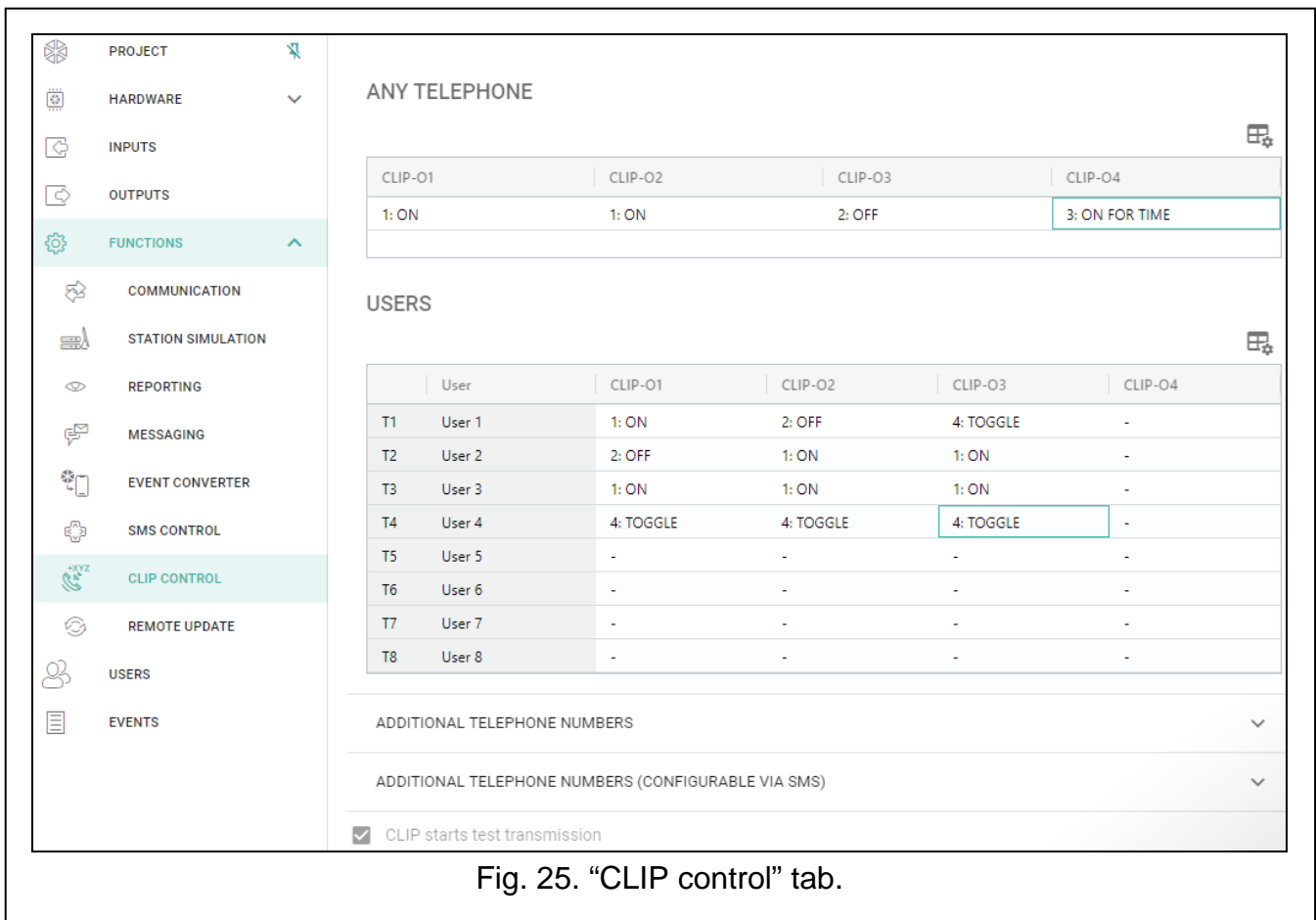



Fig. 25. “CLIP control” tab.

**Telephone number** – you can program 1024 phone numbers to control the outputs by using CLIP. You can program the whole telephone number (including the country code) or only part of it. Up to five characters (consecutive digits from any part of the number, including “+”) can be treated as part of the number. Six and more characters will be interpreted by the module as the whole telephone number.

*If you wish to program more than 1024 telephone numbers, you can do so in the “Additional telephone numbers (configurable via SMS)” table or by sending SMS messages containing appropriate control commands (see “Programming a list of additional telephones for CLIP control”).*

**Description** – you can enter description of the given telephone number. The description may contain up to 32 characters (digits, letters and special characters). The description is not saved to the module.







You can sort the data in the table. If you click on the selected column header (e.g. "Telephone number"), the table will be sorted by the data in that column. The symbol indicating the current sorting method ( – ascending,  - descending) will be displayed in the column header.

### Additional telephone numbers (configurable via SMS)

You can configure a list of 10 thousand additional telephones from which control of the module outputs will be possible by means of the CLIP service.



Before you start programming the list, click , and after you finish programming the list, click . The list will not be read from / written to the module memory when you click  /  on the GX Soft menu bar.

You can also configure the list by using the SMS commands (see "Programming a list of additional telephones for CLIP control").

The search field is displayed above the table. If you want to find a telephone number:

1. Click on the search field and enter a string of characters included in the telephone number or its description.
2. Click . The telephone numbers that meet the search criteria will be displayed.



If you want to display all telephone numbers, click  in the search field (this will clear all the characters entered in the field).



– click to read the list of numbers from the module.



– click to write the list of numbers to the module.



– click to import the telephone numbers from the file.



– click to export the telephone numbers to the file.



– click to hide blank rows in the table.



– click to show blank rows in the table.



– click to delete the selected rows in the table (selected telephone numbers).



– click to show the table options. The options enable you to hide / show the selected columns in the table and to fit the columns to its content or to the width of the window.

**Telephone number** – you can program 10 thousand phone numbers to control the outputs by using CLIP. You can program the whole telephone number (including the country code) or only part of it. Up to five characters (consecutive digits from any part of the number, including "+") can be treated as part of the number. Six and more characters will be interpreted by the module as the whole telephone number.

**Description** – you can enter description of the given telephone number. The description may contain up to 32 characters (digits, "." and "@" characters, lower and upper case letters without diacritical marks). The description is saved to the module.

### Output control

**CLIP-O1...O4** – the output can respond to CLIP in one of the following ways:

**0:** - – CLIP does not control the output.

**1: ON** – CLIP will turn on the output.

**2: OFF** – CLIP will turn off the output.

**3: ON FOR TIME** – CLIP will turn on the output for a specified period of time (see "Operating time" parameter p. 23).

**4: TOGGLE** – CLIP will switch the output to its opposite status.

If several different responses to CLIP from one telephone number are programmed for the given output (e.g. O1) (when the number or part of it is programmed in two or more rows of the table), then in response to CLIP from that number the output will be switched over successively to each of the programmed statuses. The switching sequence will correspond to the consecutive numbers from the telephone list.

**CLIP starts test transmission** – information about additional reaction of the module to CLIP. If the option is enabled, a test transmission will be additionally started by the module in response to CLIP. You can enable/disable this option in the “Mainboard” tab (see “CLIP starts test transmission” p. 19).

## 6.14 Remote update

Remote update of the module firmware is made possible by the “UpServ” update server, which is included in the SATEL product portfolio.

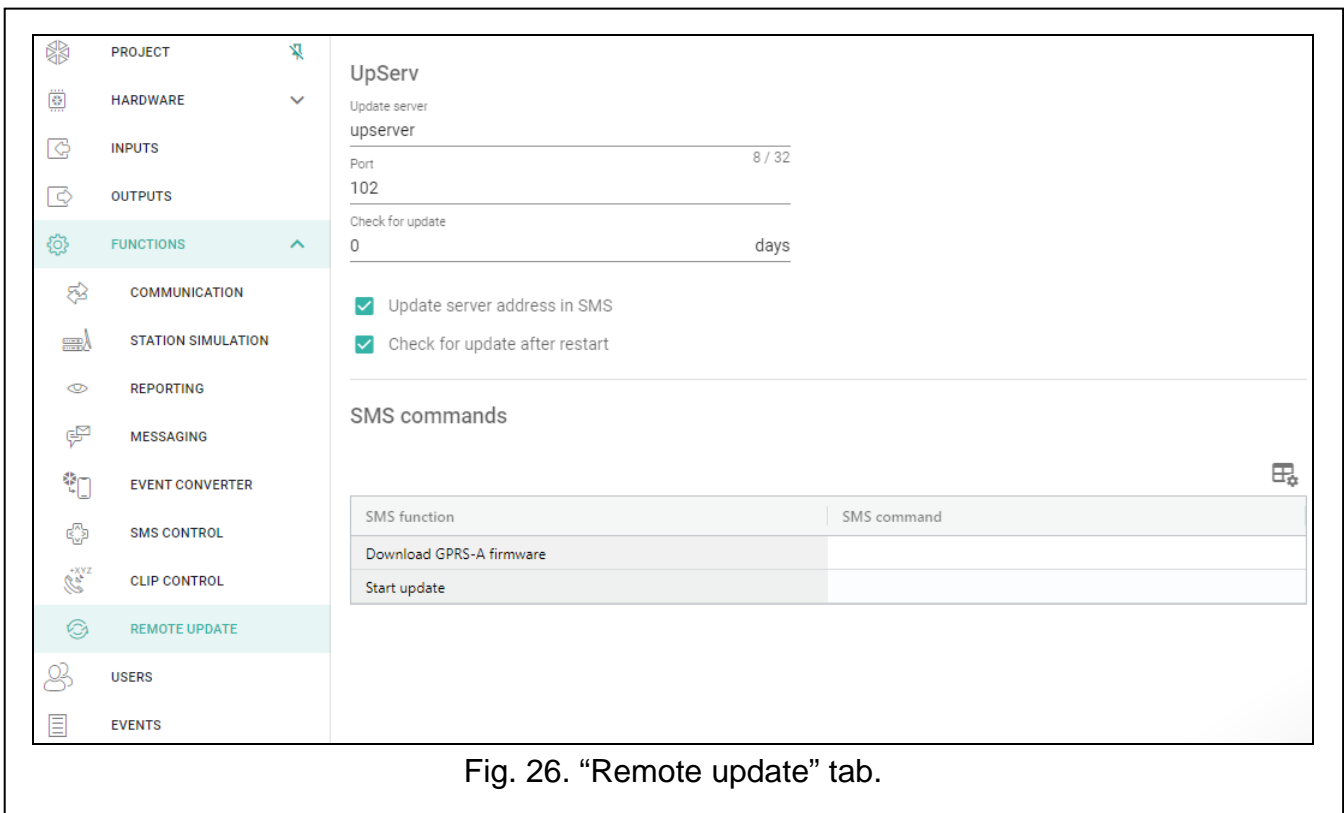



Fig. 26. “Remote update” tab.

### UpServ

**Update server** – address of the “UpServ” update server. You can enter the IP address or domain name.

**Port** – number of the TCP port used for communication with the “UpServ” update server. You can enter values from 0 to 65535 (0=disabled).

**Check for update** – you can define every how many days the module will check for a new firmware version. You can enter from 0 to 31. If you enter 0, checking will be disabled.

 – click to start remote firmware update.

**Update server address in SMS** – if this option is enabled, you can enter server address and port number in the SMS message initiating the firmware download from the update server. If the message contains no address or port number, the module will use the preprogrammed settings.

**Check for update after restart** – if this option is enabled, the module will connect to the update server after each restart and check if a new firmware version is available.

**SMS commands**

 – click to show the table options. The options enable you to hide / show the selected columns in the table and to fit the columns to its content or to the width of the window.

**SMS function** – function run after control command is received. The functions are used for remote update of the module.

**SMS command** – the control command which, if sent in the SMS message, will start the function. You can enter up to 16 alphanumeric characters except spaces (digits, letters and special characters).

 *The content of control commands must vary.*  
*The content of one control command must not be inserted into the content of another command.*  
*If you program the command initiating firmware download without programming the command that initiates update of the firmware, the update will start automatically after the download is completed.*

**6.15 Users**

You can enter data of 8 users. It will be possible to control the module from the user telephone number by using SMS messages (see p. 35) and CLIP (see p. 37). At the same time, the module can send notifications (SMS and CLIP) of the events (see p. 32) to the user telephone number.

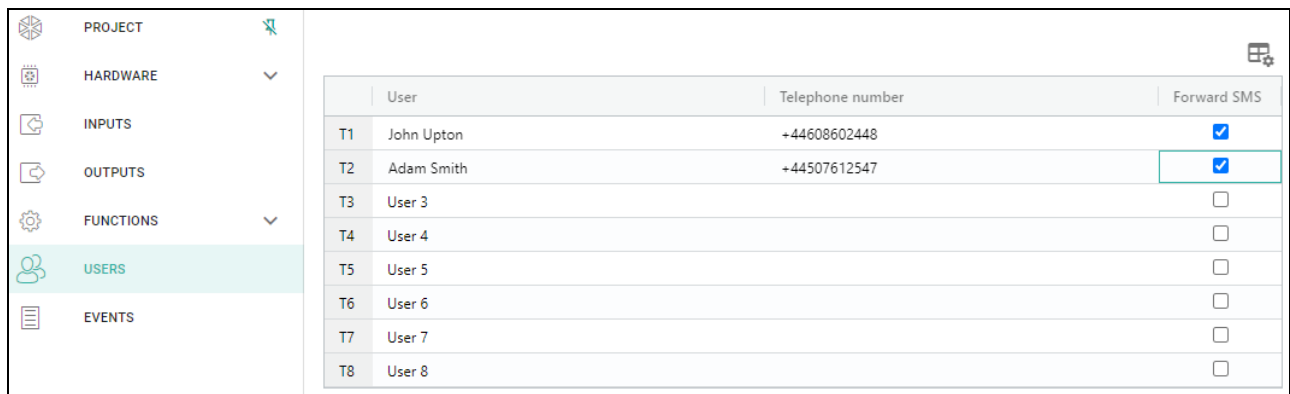

	User	Telephone number	Forward SMS
T1	John Upton	+44608602448	<input checked="" type="checkbox"/>
T2	Adam Smith	+44507612547	<input checked="" type="checkbox"/>
T3	User 3		<input type="checkbox"/>
T4	User 4		<input type="checkbox"/>
T5	User 5		<input type="checkbox"/>
T6	User 6		<input type="checkbox"/>
T7	User 7		<input type="checkbox"/>
T8	User 8		<input type="checkbox"/>

Fig. 27. "Users" tab.

 – click to show the table options. The options enable you to hide / show the selected columns in the table and to fit the columns to its content or to the width of the window.

**User** – individual name of the user (up to 16 characters).

**Telephone number** – the user telephone number. You can program the whole telephone number (including the country code) or only part of it. Up to five characters (consecutive digits from any part of the number, including "+") can be treated as part of the number. Six and more characters will be interpreted by the module as the whole telephone number.

**Forward SMS** – if this option is enabled, unknown SMS messages received by the module are forwarded to the user phone number (e.g. information received from the cellular network operator).

## 6.16 Events

Up to 500 events generated by the module or received from the control panel can be recorded in the module non-volatile memory.

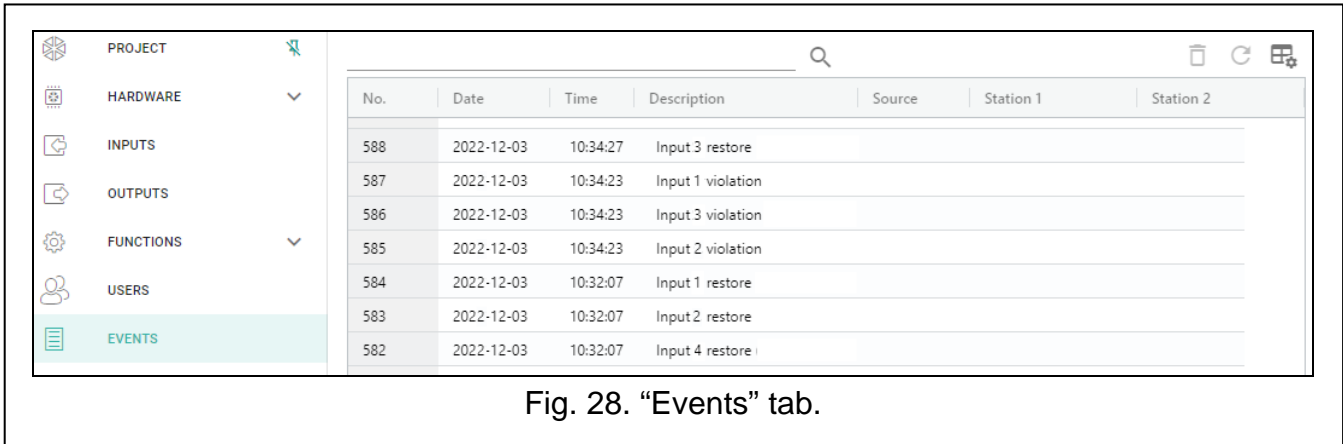

Fig. 28. "Events" tab.

The search field is displayed above the table. If you want to find an event:

1. Click on the search field and enter a string of characters contained in the event details (e.g. the event description or date of its occurrence).
2. Click . Events that meet the search criteria will be displayed.

If you want to go back to all events, click in the search field (this will clear all the characters entered in the field).

– click to clear the module event log.

– click to refresh the list of events (new events read from the module memory will be added to the list of events).

– click to show the table options. The options enable you to hide / show the selected columns in the table and to fit the columns to its content or to the width of the window.

You can sort the data in the table. If you click on the selected column header (e.g. "Date"), the table will be sorted by the data in that column. The symbol indicating the current sorting method ( – ascending, - descending) will be displayed in the column header.

Events are shown sorted by time in descending order (the latest UP, the oldest DOWN). Individual columns present the following information:

**No.** – consecutive event number.

**Date** – date the event occurred in the module / event from the control panel was saved to the module memory (see "Events buffering" p. 26).

**Time** – hour the event occurred in the module / event from the control panel was saved to the module memory (see "Events buffering" p. 26).

**Description** – event description (for events in Contact ID or SIA format).

**Source** – name of source that generated the event.

**Station 1 / Station 2** – reporting status:

**[blank field]** – event is not reported,

**?** – event waiting to be sent to the monitoring station,

**+** – test transmission sent to the monitoring station,

**-** – sending test transmission has failed,

**\*** – sending event cancelled (e.g. reporting has been disabled),

**[name of reporting path]** – event sent successfully to the monitoring station using the given transmission path.

## 7. Control by using a telephone

---

### 7.1 SMS control

---

#### Required settings

- Program the control commands (see section “SMS control” p. 35).
- If the control availability is to be limited to the telephones whose numbers have been programmed in the module for users (see “Users” p. 41), enable the “Users tel. numbers” option (p. 19).
- If module is to confirm execution of the control command by means of SMS message, program SMS center number (see “SMS center number” p. 21) and enable the “Confirm control by sending module status” option (p. 35).

#### Control

1. Send the SMS message containing a control command to the module cellular telephone number.



*The control command may be just a fragment of the SMS message, but it must be among the first 32 characters. This makes it is possible to write the control command, including the comments, to the telephone memory and send the whole to the module.*

*Several control commands may be included in one SMS message (should be separated by spaces).*

2. If the “Confirm control by sending module status” option (p. 35) is enabled, after execution of the command the module will send an SMS message with the information on module status:

“OT=????, IN=????????, AC=?, SIG=?, P=?, ??:?? / ??d??h??m, T1=??, T2=??, T3=??, T4=??, T5=??, T6=??, T7=??, T8=??,”

where:

OT – information on output status [o – output OFF; O – output ON].

IN – information on input status [i or t – input in normal status; I or T – input violated; b – input bypassed].

AC – information on AC input status [i – alternate voltage present; I – no alternate voltage].

P – information on the current module supply voltage [V].

SIG – actual level of signal received by antenna [digits from 0 to 4].

?:?:? / ??d??h??m – information on how many days, hours and minutes the module sends the test transmission [once a day at e.g. 15:10 / number of days (d), hours (h) and minutes (m)].

T1...T8 – information on the user telephone numbers programmed in the module.

### 7.2 CLIP control

---

Using the CLIP you can only control the status of outputs.

#### Required settings

- Enter the telephone numbers from which control of the outputs will be possible by means of CLIP (see section “CLIP control” p. 37).
- Define from which telephone numbers and how the outputs are to be controlled by CLIP (see “CLIP-O1...O4” p. 39).

## Control

Call the module cellular telephone number and hang up after hearing the ring signal. The module will change the output status. If the “Send SMS with module status on CLIP” option (p. 19) is enabled in the module, the module will send an SMS with module status information to your telephone number.

## 8. Module firmware update

---



*When the firmware update is running, the module does not execute its normal functions.*

*Save the module settings before you run the firmware update.*

### 8.1 Local update

---

1. Download the update program for GPRS-A Lite module firmware from [www.satel.pl](http://www.satel.pl).
2. Connect the module USB (Micro-B) port with the computer port.
3. Run the update program for module firmware.
4. Click the  button.
5. When a prompt window is displayed asking you whether to continue the firmware update, click “Yes”. The firmware of module will be updated.

### 8.2 Remote update

---

1. Program the parameters for remote update of the module firmware in the module (see “Remote update” p. 40).
2. Initiate the update from the GX Soft program (see p. 40) or by using an SMS message.

#### 8.2.1 Initiating the update by using SMS message



*The SMS messages which initiate the download and update of firmware can only be sent from an authorized telephone number (see “Tel. numbers verification (SMS control and answer to CLIP)” p. 19).*

1. Send to the number of SIM card used by the module an SMS message containing control command to initiate firmware download from the “UpServ” update server (see “SMS command” p. 41). If the “Update server address in SMS” option is enabled in the module and you want the module to connect to an update server other than that indicated in the module settings, the message should look like this: **xxxx=aaa:pp=** (“xxxx” – control command; “aaa” – server address (IP address or domain name); “pp” – port number).
2. Completion of the new firmware download will be indicated by the module with an SMS message.
3. Send an SMS message containing the control command to initiate the module firmware update (see “SMS command” p. 41). If the update initiating control command has not been programmed in the module, the firmware update process will be started automatically by the module after the download is completed.
4. Completion of the module firmware update will be indicated by the module with an SMS message.

## 9. Restoring the factory settings

---

1. Click the “Project” tab in the GX Soft program.
2. Click the “Factory settings” button. You will be prompted whether to restore the factory settings.
3. Click “Yes”.

## 10. Specifications

---

Number of inputs .....	4
Number of outputs (OC type).....	4
Supply voltage .....	12 VDC $\pm$ 15%
Standby current consumption .....	80 mA
Maximum current consumption.....	220 mA
Maximum permissible voltage on AC input .....	up to 25 VAC
OC type outputs.....	50 mA / 12 VDC
Environmental class according to EN50130-5 .....	II
Operating temperature range.....	-10...+55°C
Maximum humidity .....	93 $\pm$ 3%
Enclosure dimensions.....	83 x 65 x 23 mm
Weight.....	71 g